



1 9 9 2



MIYATA

materials & technologies...

UNIDIRECTIONAL THERMOSET GRAPHITE / EPOXY COMPOSITE [CARBON FIBER]:

ULTIMATE PERFORMANCE TECHNOLOGY, STRAIGHT FROM THE U.S. AEROSPACE PROGRAM. LAMINATED AROUND A THIN SLEEVE OF TEMPERED ALUMINUM FOR SUPERIOR IMPACT RESISTANCE AND A STRONGER, CORROSION-FREE BOND. THEN APA-BONDED TO PRECISION CAST ALUMINUM LUGS TO PRODUCE A FINISHED FRAME 30% LIGHTER THAN STEEL, 16% STRONGER, AND SEVEN TIMES AS SHOCK ABSORBENT.

INTRODUCTORY

TITANIUM ALLOY:

STRONGER THAN STEEL, YET LIGHTER THAN ALUMINUM. AND, UNTIL RECENTLY, THE WORLD'S MOST EXPENSIVE FRAME MATERIAL. BUT NOW MIYATA'S APA-BONDING PROCESS DELIVERS FAMOUS TITANIUM PERFORMANCE WITHOUT THE HIGH COST OR POTENTIAL LOSS OF MATERIAL INTEGRITY ASSOCIATED WITH INERT-GAS WELDING.



CARBON FIBER

- ① PROTECTIVE CLEAR COAT.
- ② 45/45 CLOTH PREPREG.
- ③ UNI-DIRECTIONAL PREPREG.
- ④ 45/45 CLOTH PREPREG.
- ⑤ 90/90 CLOTH PREPREG
- ⑥ ISOLATOR
- ⑦ 6000-SERIES ALUMINUM, SPECIAL ALLOY, TEMPERED.

TITANIUM

STB [SPLINED TRIPLE-BUTTED] CHROME-MOLY:

UNLIKE OTHER MANUFACTURERS, MIYATA CUSTOM-DRAWS CHROME-MOLY TUBING IN ITS OWN MILL TO PRODUCE A PERFECT MARRIAGE OF THE FRAMEBUILDER'S ART WITH 21ST-CENTURY MIYATA TECHNOLOGY. DIRECTIONAL TRIPLE-BUTTING AND A SPIRALED INTERNAL RIB MATCH EACH TUBE'S DYNAMIC REQUIREMENTS FOR A LIGHTER, STIFFER, MORE RESILIENT FRAMESET.

STB CHROME-MOLY



IN THE LAST HUNDRED YEARS MIYATA HAS BUILT MORE THAN JUST FINE BICYCLES AND FRAMESETS. WE'VE ALSO CREATED AN INTERNATIONAL REPUTATION FOR QUALITY, DURABILITY, AND INNOVATION UNMATCHED ANYWHERE IN THE INDUSTRY.

SO IN THE RACE TO DEVELOP NEW FRAMEBUILDING MATERIALS AND TECHNOLOGIES, IT'S NO SURPRISE TO FIND MIYATA LEADING THE PACK.

WITH INNOVATIONS AS SOPHISTICATED AS OUR EXCLUSIVE APA [ALUMINUM PRESSURIZED ADHESIVE] BONDING PROCESS — A 4,200 POUND-PER-SQUARE-INCH TECHNOLOGY THAT PRODUCES BONDS UP TO DOUBLE THE STRENGTH OF BRAZED STEEL JOINTS — EVEN STRONGER THAN THE TUBES AND LUGS THEY HOLD TOGETHER.

OR AS SIMPLE AS HAVING ONE OF THE WORLD'S FASTEST OFF-ROAD RACERS — GREG HERBOLD — DESIGNING PARTS AND ACCESSORIES.

OR AS FAR-REACHING AS TAKING ADVANTAGE OF THE ENTIRE SPECTRUM OF HIGH-PERFORMANCE FRAMEBUILDING MATERIALS, INSTEAD OF A SELECT FEW. AND BUILDING BIKES THAT MAXIMIZE THE UNIQUE PERFORMANCE POTENTIAL OF EACH.

IN THE PAGES THAT FOLLOW, THE CHOICE IS YOURS. SELECT FROM VIBRATION-ABSORBING CARBON FIBER, SPACE-AGE TITANIUM, AIRCRAFT-GRADE ALUMINUM, OR TRADITIONAL AND PROVEN CHROME-MOLY DESIGNS.

WHATEVER YOUR RIDING STYLE — ON-ROAD, OFF-ROAD, BACKROADS, OR CITY STREETS; RACING, TOURING, AROUND TOWN OR JUST FOR FUN — YOU'LL FIND A MIYATA THAT'S RIGHT FOR YOU. BUILT AND BACKED WITH THE CONFIDENCE THAT COMES WITH MORE THAN A HUNDRED YEARS OF CRAFTSMANSHIP.



ALUMINUM - APA

6000 SERIES HEAT-TREATED AIRCRAFT-GRADE ALUMINUM:

APA BONDING MAXIMIZES THE QUALITIES ALUMINUM IS PRIZED FOR WITHOUT DANGER OF WARPAGE OR LOSS OF TUBE STRENGTH FROM HIGH-TEMPERATURE TIG WELDING.

SEVEN-STEP FINISHING PROCESS:

FIRST IT'S POLISHED AND TREATED WITH ZINC PHOSPHATE TO IMPROVE PAINT ADHESION AND TO ELIMINATE RUSTING. THE FRAME IS PAINTED, USING THE LATEST ELECTROSTATIC TECHNIQUES, WITH LAYERS OF PRIMERS AND FINISHING LACQUERS. AFTER DECALS, A TOPCOAT OF HARD, CLEAR ACRYLIC IS APPLIED TO ADD A FINAL DEEP LUSTRE, AND TO PROTECT THE DECALS.



THE RESULT IS A TRUE MIYATA CLASSIC: 27% LIGHTER THAN STEEL, FAR MORE RIGID, AND — UNLIKE WELDED ALUMINUM FRAMES — PERFECTLY ALIGNED, EVERY TIME.





NO FRILLS HERE.
NO GEE-WHIZ GIMMICKS.
JUST hardcore, bottom-line
performance. AND A GALAXY OF
ENGINEERING ADVANTAGES TO HELP
SEPARATE YOU FROM THE PACK.

LIKE WIDE-CLEARANCE DELTA
FORCE SEATSTAYS. SHORT, CURVED
16.75" AIR COBRA CHAINSTAYS,
BOTTOM BRACKET MOUNTED
STAINLESS STEEL, STAIR-STEPPED
PLATE, TO PREVENT CHAIN SUCK.
CONTOURED HEAD LUGS FOR LESS
WEIGHT AND MORE STRENGTH.
EVEN AN ECCENTRIC BOTTOM
BRACKET DESIGN THAT LOWERS
CHAINSTAYS FOR INCREASED CHAIN
CLEARANCE TO MINIMIZE CHAIN
SLAP.

ALL THINGS CONSIDERED, ONE OF
THE MOST THOROUGHLY THOUGHT-
OUT LINES OF OFF-ROAD MACHINES
EVER ASSEMBLED. AND, QUITE
POSSIBLY, THE FASTEST.

HOW DO WE KNOW? SIMPLE. OUR
OFF-ROAD BIKES ARE DESIGNED AND
PROTOTYPED AT THE MOST
SOPHISTICATED RESEARCH AND
TESTING FACILITY IN THE INDUSTRY.
THEN FIELD-TESTED UNDER THE
MOST BRUTAL CONDITIONS IN
PROFESSIONAL RACING BY NORBA
② PRO GREG HERBOLD.

YOU REMEMBER GREG, RIGHT?
PH.D. IN SPEED? HUMAN
CANNONBALL? ① THE GUY WHO
AVERAGED 65 MPH IN LAST
YEAR'S KAMIKAZE DOWNHILL?

YEAH, THAT GREG HERBOLD. A
GUY WHO MAKES IT A PERSONAL
RESPONSIBILITY TO HELP KEEP EVERY
MIYATA OFF-ROAD MACHINE A FEW
SECONDS AHEAD OF THE
COMPETITION.

WHICH WORKS OUT VERY WELL FOR
US. AND FOR GREG. AND, IF
YOU'RE ON A MIYATA, FOR YOU.

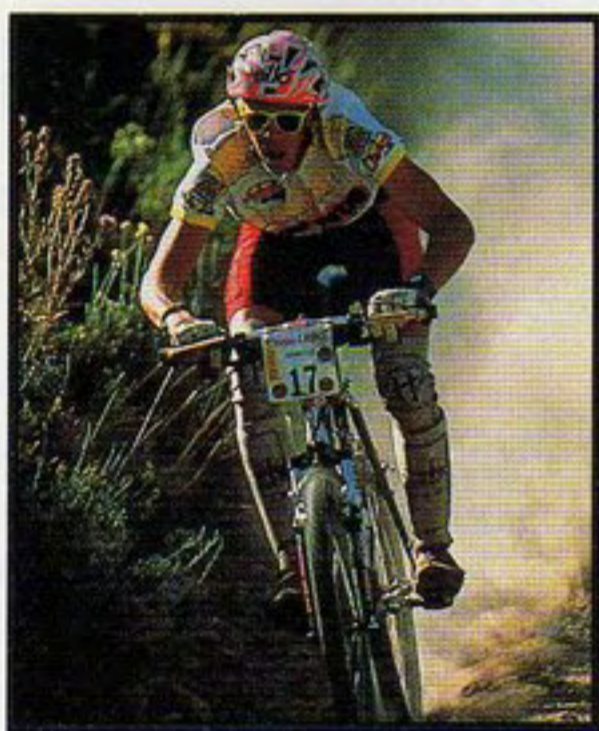

What 65 mph looks like.

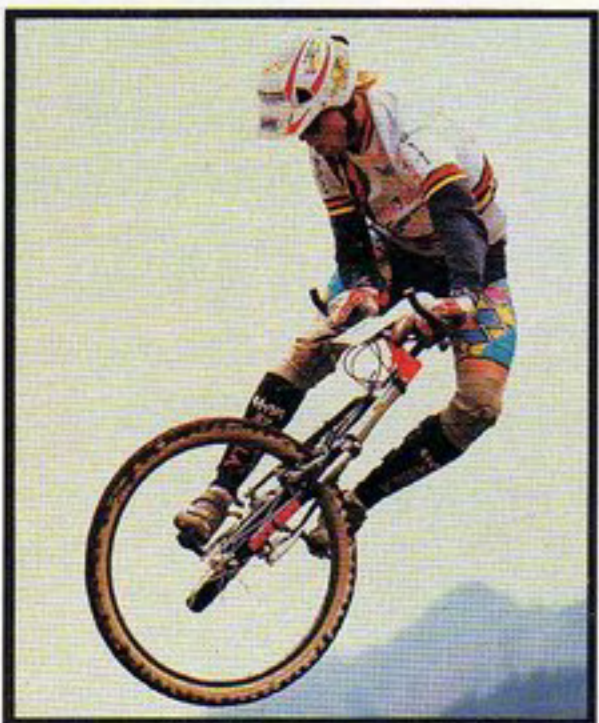

G.H. SPECIAL TIRES

Greg worked with Miyata's computer design team to develop complementary front and rear tread patterns: wider-spaced front knobs and round profile provide increased braking and cornering control, while special "HB" tread pattern and square profile give unequalled rear end performance even under the most severe traction situations. The perfect combination for single-track, high-speed switchbacks, fast technical sections, and all-out runs against the clock.

A few more reasons Greg Herbold - and Miyata - will be off the front again this year:

HERBOLD COMPETITION GRIPS

Anatomic hexagonal contour, "Hairball-designed" to fit your hand perfectly. Narrow profile design allows the use of a thicker glove preferred by pro/elite riders. Special ribbed pattern at high pressure areas improves shock absorption and prevents slipping, even on sweat-soaked climbs.

HERBOLD PERFORMANCE SADDLE

Most saddles found on ATB's are designed for road bikes. So Greg spec'd his and ours, with a longer, narrower profile for improved fore/aft adjustment and thigh clearance. Then Greg carved away unnecessary material for streamlining and rider comfort, and added 3 special high-contact patches to protect against cutting in crashes. A dynamite performer.

ROCK SHOX
OPTION
AVAILABLE

ELEVATION 7,000' & 5,000' FRAME GEOMETRY [mm]

	A TOP TUBE	B REAR CENTER	C FRONT CENTER	D WHEEL BASE	E BB DROP	F OFF SET.	a HEAD ANGLE	b SEAT ANGLE	d STAND OVER HT	e BB HEIGHT	TOP TUBE SLOPING
14.5"	530	425	608	1031	35	46	71°	73°	710	300	22°
16.5"	545	425	626	1048	35	46	71°	73°	732	300	16°
18.5"	565	425	643	1065	35	46	71°	73°	752	300	10°
20.5"	585	425	655	1077	35	46	71°	73°	771	300	4°

1
CARBON FIBER
APA BONDED
FRAME WITH
ALUMINUM STAYS

2
NEW FAT MAX II
CHROME-MOLY
FORK

3
SUNTOUR XC
COMP MICRODRIVE
DRIVETRAIN WITH
TOP MOUNT
SHIFTERS

4
SUNTOUR XC
COMP SUPER LOW
PROFILE BRAKES

5
GREG HERBOLD
SPECIAL SADDLE,
GRIPS AND TIRES

6
RITCHEY FORCE
STEM WITH ALLOY
BAR

7
ARAYA RM 17 RIMS

8
COLOR:
NATURAL CARBON
WITH HYSTERIA



ELEVATION 7,000'

SAME CARBON MAIN FRAME AS OUR TOP-OF-THE-LINE BIKE, BUT WITH A SHOCK-ABSORBING ALUMINUM REAR TRIANGLE THAT, AS GREG PUTS IT, "ACTS AS A PASSIVE SUSPENSION SYSTEM". SUNTOUR XC COMP COMPONENTS, MICRO-DRIVE POWER PLANT AND FULL HERBOLD PERFORMANCE PACKAGE. ONE OF GREG'S FAVORITES.

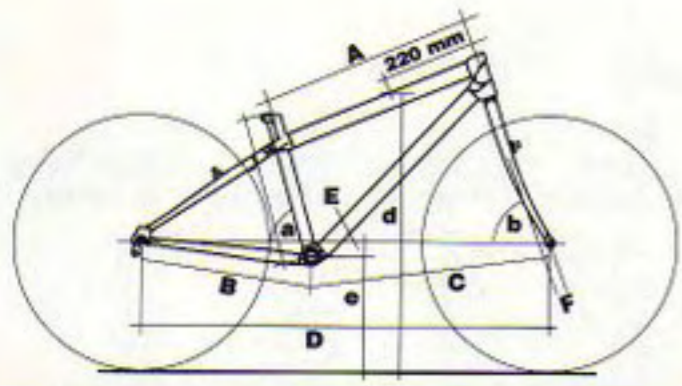

- ① FULL ALUMINUM
APA BONDED
FRAME
- ② NEW FAT MAX II
CHROME-MOLY
FORK
- ③ SHIMANO DEORE
XT DRIVETRAIN
WITH TOP PULL
FRONT DERAILLEUR
AND TOP MOUNT
SHIFTERS
- ④ SHIMANO DEORE
XT SLR LOW
PROFILE
CANTILEVER
BRAKES WITH
TWO-FINGER LEVER
- ⑤ GREG HERBOLD
SPECIAL SADDLE,
GRIPS AND TIRES
- ⑥ RITCHEY FORCE
STEM WITH ALLOY
BAR
- ⑦ ARAYA RM 17
RIMS
- ⑧ COLOR:
NEW PATRIOT

ELEVATION 5,000'

OVERSIZE ALUMINUM FRAME AND FAT MAX II FORK DELIVER THE RIDE AND DURABILITY THAT HAVE MADE MIYATA'S APA BONDING PROCESS THE INDUSTRY'S QUALITY STANDARD. HIGH-SPEED STABILITY, LOW-SPEED MANEUVERABILITY, FULL DEORE XT COMPONENTRY, AND A PRICE TAG TO GIVE ALL LEVELS OF RIDERS THE PERFORMANCE OF A FULL-BLOWN COMPETITION MACHINE.



MITCH AND MICHELLE PUT MIYATA'S MOUNTAIN BIKES TO THE TEST ON THE TOUGH NORBA RACING CIRCUIT.

ROCK SHOX
OPTION
AVAILABLE

ELEVATION 3,000' & 2,000' FRAME GEOMETRY [mm]

	A TOP TUBE	B REAR CENTER	C FRONT CENTER	D WHEEL BASE	E BB DROP	F OFF SET.	a HEAD ANGLE	b SEAT ANGLE	d STAND OVER HT	e BB HEIGHT	TOP TUBE SLOPING
14.5"	530	425	608	1031	35	46	71°	73°	710	300	22°
16.5"	545	425	626	1048	35	46	71°	73°	732	300	16°
18.5"	565	425	643	1065	35	46	71°	73°	752	300	10°
20.5"	585	425	655	1077	35	46	71°	73°	771	300	4°

- ① CARBON FIBER APA BONDED FRAME WITH CHROME-MOLY STAYS
- ② NEW FAT MAX II CHROME-MOLY FORK
- ③ SHIMANO DEORE DX DRIVETRAIN WITH TOP PULL FRONT DERAILLEUR AND TOP MOUNT SHIFTERS
- ④ SHIMANO DEORE DX SLR LOW PROFILE CANTILEVER BRAKES WITH TWO-FINGER LEVERS
- ⑤ GREG HERBOLD SPECIAL SADDLE, GRIPS AND TIRES
- ⑥ RITCHEY FORCE STEM WITH ALLOY BAR
- ⑦ ARAYA CV 7 RIMS
- ⑧ COLOR: NATURAL CARBON WITH HYSTERIA



PROFESSIONAL RACER AND WINNER OF THE 1990 WORLD DOWNHILL CHAMPIONSHIPS, GREG HERBOLD IS A KEY MEMBER OF THE MIYATA DESIGN TEAM, FIELD TESTING MIYATA BICYCLES IN DAILY TRAINING AND INTERNATIONAL RACES.

ELEVATION 3,000'

COMBINE APA-BONDED CARBON-FIBER STABILITY AND TRACKING WITH THE SMOOTH, RESPONSIVE RIDE OF CHROME-MOLY STAYS, DEORE DX COMPONENTRY AND GREG HERBOLD RACING ACCESSORIES, AND YOU'VE GOT A GREAT VALUE FOR THE PERFORMANCE-MINDED ENTHUSIAST.

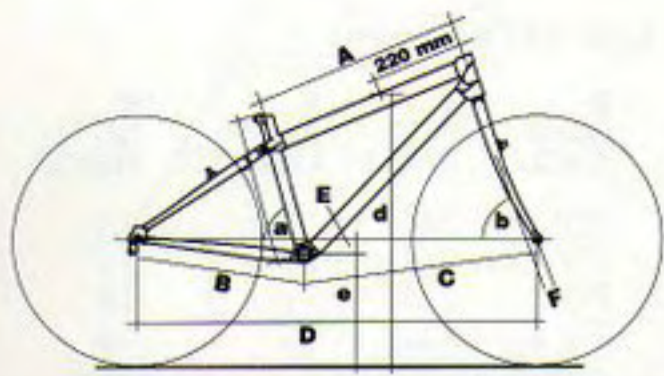

- ① ALUMINUM APA BONDED FRAME WITH CHROME-MOLY STAYS
- ② NEW FAT MAX II CHROME-MOLY FORK
- ③ SHIMANO DEORE DX DRIVETRAIN WITH TOP PULL FRONT DERAILLEUR AND TOP MOUNT SHIFTERS
- ④ SHIMANO DEORE DX SLR LOW PROFILE CANTILEVER BRAKES WITH TWO-FINGER LEVERS
- ⑤ GREG HERBOLD SPECIAL SADDLE, GRIPS AND TIRES
- ⑥ RITCHEY FORCE STEM WITH ALLOY BARS
- ⑦ ARAYA CV 7 RIMS
- ⑧ COLOR: PLATINUM

ELEVATION 2,000'

PRESENTING THE ELEVATION 2,000' PERFORMANCE PACKAGE. START WITH A MIYATA EXCLUSIVE APA-BONDED OVERSIZE ALUMINUM MAIN FRAME. ADD A FAT MAX II FORK. DRESS IT IN FULL DEORE DX COMPONENTS WITH RITCHEY FORCE ACCENTS. AND WRAP IT UP WITH GREG HERBOLD COMPETITION ACCENTS. NOW COMES THE FUN PART: TAKE THE FINISHED PACKAGE OUT TO THE NEAREST DIRT AND OPEN IT UP.



ELEVATION 1,000' , 500' & 400' FRAME GEOMETRY [mm]

	A TOP TUBE	B REAR CENTER	C FRONT CENTER	D WHEEL BASE	E BB DROP	F OFF SET.	a HEAD ANGLE	b SEAT ANGLE	d STAND OVER HT	e BB HEIGHT
14"	535	424	630	1051	38	48	70°	74°	704	38
16"	555	424	647	1068	38	48	70°	74°	725	38
18"	572	424	653	1074	38	48	70°	73°	760	38
19.5"	584	424	653	1074	38	48	70.5°	72.5°	773	38
21"	592	424	659	1080	38	48	70.5°	72.5°	807	38



- ① MIYATA EXCLUSIVE STB CHROME-MOLY FRAME
- ② FULL CHROME-MOLY UNICROWN FORK
- ③ SHIMANO DEORE DX DRIVETRAIN WITH TOP PULL FRONT DERAILLEUR AND TOP MOUNT SHIFTER
- ④ SHIMANO DEORE DX SLR LOW PROFILE CANTILEVER BRAKES WITH TWO-FINGER LEVERS
- ⑤ HEAT-TREATED CHROME-MOLY STEM WITH ALLOY BAR
- ⑥ ARAYA RM 17 RIMS, RITCHEY MEGABITE TIRES
- ⑦ VELO GEL LITE SADDLE
- ⑧ COLORS: CANDY RED OR CHARCOAL BLUE

ELEVATION 1,000'

FROM THE PREMIUM SPLINED TRIPLE-BUTTED CHROME-MOLY FRAME TO THE STURDY, CHROME-MOLY FORKS, THE ELEVATION 1,000' IS PURE OFF-ROAD PERFORMANCE: FLAT-OUT, WIDE-OPEN, AND JUST AS HARD AS YOU CAN PUSH IT. WITH FULL DEORE DX. RITCHEY MEGABITE TIRES. AND ALL THE TRIMMINGS, INCLUDING COMPETITION TOUCHES LIKE TOP-PULL FRONT DERAILLEUR AND TWO-FINGER BRAKE LEVERS.



TUBE: CHARCOAL BLUE, BICYCLE: CANDY RED

.....

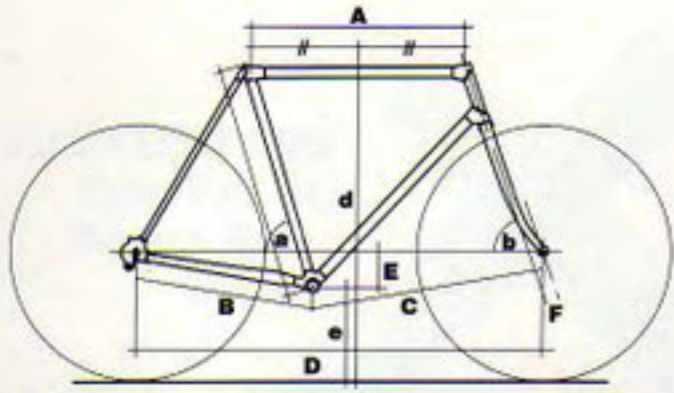

THE MIYATA
STB FRAME IS
BUILT FOR THE
ENTRY-LEVEL RACER

THE MIYATA
STB FRAME IS
BUILT FOR THE
ENTRY-LEVEL RACER



- ① MIYATA EXCLUSIVE STB CHROME-MOLY FRAME
- ② FULL CHROME-MOLY UNICROWN FORK
- ③ SHIMANO DEORE LX DRIVETRAIN WITH TOP PULL FRONT DERAILLEUR AND RAPID FIRE SHIFTER
- ④ SHIMANO DEORE LX SLR LOW PROFILE CANTILEVER BRAKES WITH THREE-FINGER LEVER
- ⑤ HEAT-TREATED CHROME-MOLY STEM WITH ALLOY BAR
- ⑥ ARAYA CV 7 BLACK RIMS, KENDA TIRES
- ⑦ VELO GEL LITE SADDLE
- ⑧ COLORS: PEARL WHITE OR NAPA GREEN

ELEVATION 500'

FULL-ON COMPETITION EQUIPMENT FOR THE ENTRY-LEVEL RACER OR ENTHUSIAST, BUILT TO TAKE ANYTHING THE DIRT CAN DISH OUT. STB CHROME-MOLY FRAME. UNICROWN CHROME-MOLY FORK. PRECISION DEORE LX COMPONENTS WITH FULL STI HYPERGLIDE/SUPERGLIDE. ALLOY BARS AND HEAT-TREATED CHROME-MOLY STEM. ELEVATION 500': NO-NONSENSE PERFORMANCE WITH A PRICE TO MATCH.



TUBE: NAPA GREEN, BICYCLE: PEARL WHITE

ELEVATION 400'
TUBE: BLUE NOVA
BICYCLE: AMETHYST

ELEVATION 300'
TUBE: DESERT SAND
BICYCLE: TAHOE GREEN

ELEVATION 400'

GREAT COMBINATION OF HIGH PERFORMANCE AND ECONOMY, BUILT AROUND A FULL STB CHROME-MOLY FRAME AND UNICROWN FORK. SHIMANO 400LX 21-SPEED RAPIDFIRE HYPERGLIDE COMPONENTS, PLUS DETAILS LIKE LOW-MAINTENANCE SEALED MECHANISM HUBS AND COMFORTABLE GEL SADDLE.

- ① STB CHROME-MOLY FRAME
- ② FULL CHROME-MOLY UNICROWN FORK
- ③ SHIMANO 400LX DERAILLEURS WITH RAPID FIRE SHIFTERS
- ④ SHIMANO 400LX LOW PROFILE BRAKES
- ⑤ VELO GEL LITE SADDLE
- ⑥ COLORS: AMETHYST OR BLUE NOVA



ELEVATION 300'

PERFECT FOR ALL-AROUND RIDING ON STREET OR DIRT. FULL CHROME-MOLY FRAME AND 21-SPEED SUNTOUR XCM PACKAGE, PRECISION DIA-COMPE CANTILEVER BRAKES WITH ADJUSTABLE-REACH LEVERS, AND COMFORTABLE GEL SADDLE.

- ① FULL CHROME-MOLY FRAME
- ② UNICROWN FORK WITH CHROME-MOLY STEERER
- ③ SUNTOUR XCM DERAILLEUR WITH THUMB SHIFTER
- ④ DIA COMPE XCM CANTILEVER BRAKES
- ⑤ VELO GEL LITE SADDLE
- ⑥ COLORS: TAHOE GREEN OR DESERT SAND



ELEVATION 400', 300', 200' & 150' FRAME GEOMETRY ON PAGE 35

ELEVATION 200'
TUBE: FIRE RED
BICYCLE: BLACK
SPARKLE



ELEVATION 200'

RELIABLE TRI-MOLY FRAME AND SMOOTH-SHIFTING SHIMANO 200GS 21-SPEED COMPONENT PACKAGE. PLUS TOUCHES USUALLY FOUND ONLY ON MORE EXPENSIVE BIKES – GEL SADDLE, LIGHTWEIGHT ALLOY RIMS, AND QUICK-RELEASE WHEELS, FRONT AND REAR.

- ❶ CHROME-MOLY MAIN FRAME
- ❷ UNICROWN FORK WITH CHROME-MOLY STEERER
- ❸ SHIMANO 200GS DERAILLEUR WITH THUMB SHIFTER
- ❹ SHIMANO 200GS CANTILEVER BRAKES
- ❺ VELO GEL LITE SADDLE
- ❻ COLORS: BLACK SPARKLE OR FIRE RED



ELEVATION 150'

MIYATA QUALITY IN AN ECONOMY PACKAGE – PERFECT FOR THE FIRST-TIME BUYER. FULL CHROME-MOLY FRAME WITH 21-SPEED SUNTOUR COMPONENTS, ALLOY RIMS, QUICK-RELEASE WHEELS AND COMFORTABLE 30MM-RISE BARS.

- ❶ CHROME-MOLY FRAME
- ❷ UNICROWN FORK WITH CHROME-MOLY STEERER
- ❸ SUNTOUR XCU DERAILLEURS WITH WISHBONE SHIFTERS
- ❹ DIA COMPE XCT CANTILEVER BRAKES
- ❺ ATB COMFORT SADDLE
- ❻ COLORS: RED JASPER OR SIERRA GREEN





FF-ROAD BIKES ARE SPECIALLY BUILT TO HANDLE ABUSE AND CONDITIONS MOST RIDERS NEVER SEE. KNOBBY TIRES, EXTRA-STABLE GEOMETRY, AND HEAVY-DUTY CONSTRUCTION ARE ALL GREAT FEATURES, IF YOU SPEND YOUR TIME POUNDING DOWN BOULDER-STREWN TRAILS AND BLASTING THROUGH RIVERS.

BUT NOW, FOR THE VAST MAJORITY OF CYCLISTS AND RIDING SITUATIONS, THERE'S A BETTER WAY. IT'S CALLED THE MIYATA CROSS SERIES. AND IT JUST MAY BE THE BIGGEST THING TO HAPPEN TO CYCLING SINCE THE MOUNTAIN BIKE.

BECAUSE MIYATA CROSS BIKES FEATURE THE SAME UPRIGHT RIDING POSITION AS A MOUNTAIN BIKE, SAME COMFORTABLE SADDLE, SAME GREAT SURE-FOOTED HANDLING. WITH A LIGHTER FRAME. QUICKER GEOMETRY. AND A PAIR OF LIGHTWEIGHT, FASTER-ACCELERATING, SMOOTH-TREAD 700x35C WHEELS THAT CAN MAKE A NIGHT-AND-DAY DIFFERENCE IN SPEED, CORNERING, AND ROAD FEEL.

MIYATA CROSS BIKES. FIVE GO-ANYWHERE FUN MACHINES THAT REALLY MAKE SENSE FOR THE WAY MOST CYCLISTS RIDE. SO, WHETHER YOU'RE EXPLORING COUNTRY LANES, DODGING CITY TRAFFIC, OR JUST OUT FOR A WEEKEND SPIN ON THE BIKE TRAIL, MIYATA HAS THE PERFECT BIKE FOR JUST ABOUT EVERY OCCASION.

The Miyata Cross bike embodies the spirited ride and nimble feel of a road bicycle with the comfortable riding position, wide gearing selection and rugged reliability of the mountain bike.



APA LUG

Miyata's exclusive APA bonding of aluminum tubes with precision cast aluminum lugs creates a frame that outperforms welded frames in durability, alignment and

ALUMICROSS & QUICKCROSS FRAME GEOMETRY [mm]

	A TOP TUBE	B REAR CENTER	C FRONT CENTER	D WHEEL BASE	E BB DROP	F OFF SET.	a HEAD ANGLE	b SEAT ANGLE	d STAND OVER HT	e BB HEIGHT
48cm	515	430	581	1006	50	60	69°	70°	761	298
50cm	525	430	584	1008	52	55	70°	71°	777	296
52cm	535	430	592	1016	56	55	70°	71°	791	292
54cm	550	430	599	1022	60	50	71°	72°	805	288
56cm	550	430	600	1023	60	50	71°	72°	824	288
58cm	560	430	608	1030	65	45	71°	72°	837	283
60cm	560	430	608	1030	65	45	71°	72°	857	283

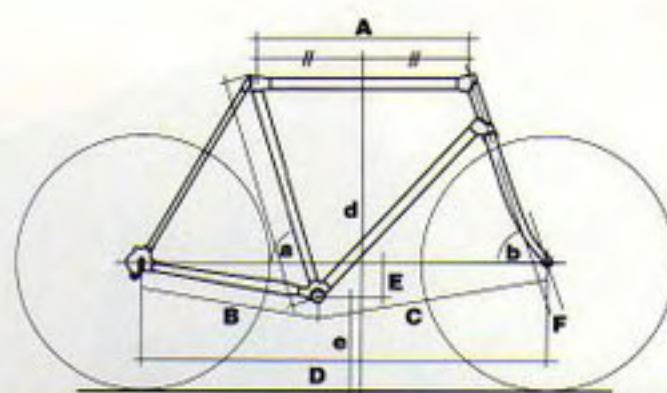

- ① ALUMINUM APA BONDED FRAME WITH CHROME-MOLY STAYS
- ② FULL CHROME-MOLY UNICROWN FORK
- ③ SHIMANO DEORE DX HYPERGLIDE DRIVETRAIN AND DERAILLEURS WITH BAR-END SHIFTERS
- ④ SHIMANO DEORE DX SLR LOW PROFILE CANTILEVER BRAKES WITH AERO LEVERS
- ⑤ WOLBER GTX S.H. ANODIZED 700C RIMS
- ⑥ 700 X 35C IRC CROSS COUNTRY TIRES
- ⑦ NITTO DYNAMIC 90 DEGREE STEM WITH ALLOY SPREAD DROP BAR
- ⑧ AVOCET RACING GEL SADDLE
- ⑨ COLOR: OPAL

ALUMICROSS

A FULL-BLOWN RACE MACHINE FOR CYCLOCROSS COMPETITION OR AN INCREDIBLE "DO EVERYTHING" BIKE... AND ONE OF THE MOST VERSATILE HYBRIDS ON THE STREET. SMOOTH-RIDING APA-BONDED ALUMINUM FRAME AND CHROME-MOLY UNICROWN FORK. SHIMANO DEORE DX/LX COMPONENTS, INCLUDING DROP BARS FOR INCREASED SPEED AND POWER, BAR-END SHIFTERS, AND CANTILEVER BRAKES WITH SLR RACING LEVERS.

ALUMICROSS & QUICKCROSS FRAME GEOMETRY [mm]

	A TOP TUBE	B REAR CENTER	C FRONT CENTER	D WHEEL BASE	E BB DROP	F OFF SET.	a HEAD ANGLE	b SEAT ANGLE	d STAND OVER HT	e BB HEIGHT
48cm	515	430	581	1006	50	60	69°	70°	761	298
50cm	525	430	584	1008	52	55	70°	71°	777	296
52cm	535	430	592	1016	56	55	70°	71°	791	292
54cm	550	430	599	1022	60	50	71°	72°	805	288
56cm	550	430	600	1023	60	50	71°	72°	824	288
58cm	560	430	608	1030	65	45	71°	72°	837	283
60cm	560	430	608	1030	65	45	71°	72°	857	283



- ① ALUMINUM APA BONDED FRAME WITH CHROME-MOLY STAYS
- ② FULL CHROME-MOLY UNICROWN FORK
- ③ SHIMANO HYPERGLIDE DRIVETRAIN AND DERAILLEURS WITH RAPID FIRE SHIFTERS
- ④ SHIMANO 300LX CANTILEVERS WITH THREE-FINGER LEVERS
- ⑤ ARAYA PX 45 700C RIMS
- ⑥ 700 X 35C PANARACER KHARTOUM TIRES
- ⑦ SR ALLOY STEM WITH POWER BULGE BLACK BAR
- ⑧ AVOCET RACING GEL SADDLE
- ⑨ COLOR: MYSTIC BLUE

QUICKCROSS

PERFECT FOR THE PERFORMANCE RIDER, OR AS A STREET MACHINE FOR THE OFF-ROAD RACER. STIFF, LIGHTWEIGHT MIYATA ALUMINUM FRAME, FULL CHROME-MOLY FORK, AND A COMPETITION PACKAGE FEATURING SHIMANO 500/400LX TRANSMISSION, AVOCET RACING GEL SADDLE, AND FAST-ACCELERATING, DURABLE-TREAD KHARTOUM CROSS TIRES ON NARROW ARAYA PX 45 RIMS.



APA LUG
 APA-ALUMINUM PRESSURIZED ADHESIVE BONDING RESULTS IN BONDS EVEN STRONGER THAN THE TUBES AND LUGS THEY HOLD TOGETHER.

TRIPLECROSS FRAME GEOMETRY [mm]

	A TOP TUBE	B REAR CENTER	C FRONT CENTER	D WHEEL BASE	E BB DROP	F OFF SET.	a HEAD ANGLE	b SEAT ANGLE	d STAND OVER HT	e BB HEIGHT
46cm	529	443	610	1047	55	60	71°	73°	753	294
50cm	547.5	443	615	1052	55	60	71°	73°	775	294
54cm	565	443	630	1062	55	60	71°	73°	809	294
56cm	575	443	633.5	1070	55	60	72°	73°	827	294
58cm	575	443	633	1068	55	60	72°	73°	846	294
60cm	584	443	644	1081	55	60	72°	73°	860	294
63cm	584	443	644	1081	55	60	72°	73°	879	294

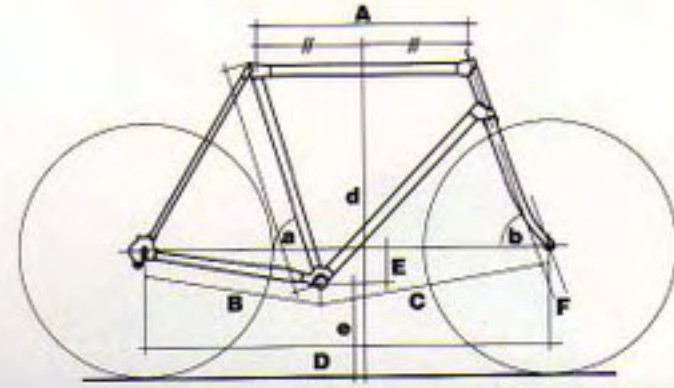

- ① EXCLUSIVE STB CHROME-MOLY FRAME
- ② FULL CHROME-MOLY UNICROWN FORK
- ③ SHIMANO 300LX HYPERGLIDE DRIVETRAIN AND DERAILLEURS WITH RAPID FIRE SHIFTERS
- ④ SHIMANO 200CX CANTILEVER BRAKES WITH THREE-FINGER LEVERS
- ⑤ ARAYA PX 45 700C RIMS
- ⑥ 700 X 35C IRC CROSS TIRES
- ⑦ TIGGED STEM WITH DOUBLE TAPER BAR
- ⑧ VELO GEL LITE SADDLE
- ⑨ COLOR: PLATINUM OR FOREST GREEN

TRIPLECROSS

CLASSIC STYLING AND HIGH-POWER CROSS PERFORMANCE. PROVEN STB CHROME-MOLY FRAME, 21-SPEED RAPIDFIRE SHIFTING, LIGHTWEIGHT 700x38C CROSS WHEELS, AND HEAD-TURNING PLATINUM FINISH MAKE THE TRIPLECROSS A STAR PERFORMER, ON ROAD OR OFF.



TUBE: FOREST GREEN, BICYCLE: PLATINUM

SPORTCROSS FRAME GEOMETRY [mm]

	A TOP TUBE	B REAR CENTER	C FRONT CENTER	D WHEEL BASE	E BB DROP	F OFF SET.	a HEAD ANGLE	b SEAT ANGLE	d STAND OVER HT	e BB HEIGHT
46cm	529	443	610	1047	55	60	71°	73°	753	294
50cm	547.5	443	615	1052	55	60	71°	73°	775	294
54cm	565	443	630	1062	55	60	71°	73°	809	294
56cm	575	443	633.5	1070	55	60	72°	73°	827	294
58cm	575	443	633	1068	55	60	72°	73°	846	294
60cm	584	443	644	1081	55	60	72°	73°	860	294
63cm	584	443	644	1081	55	60	72°	73°	879	294
46cm Ladies		443	610	1047	55	60	71°	73°	753	294
50cm Ladies		443	615	1052	55	60	71°	73°	775	294



- 1 CHROME-MOLY FRAME
- 2 UNICROWN FORK WITH CHROME-MOLY STEERER
- 3 SHIMANO HYPERGLIDE DRIVETRAIN WITH 30DLX CRANKS AND 200GS DERAILLEURS WITH RAPID FIRE SHIFTERS
- 4 SHIMANO 200CX CANTILEVER BRAKES WITH THREE-FINGER LEVERS
- 5 ARAYA SP 20 700C RIMS
- 6 700 X 35C CROSS TIRES
- 7 TIGGED STEM WITH DOUBLE TAPER BAR
- 8 VELO GEL LITE SADDLE
- 9 COLOR: FIRE RED OR IRIS BLUE

SPORTCROSS

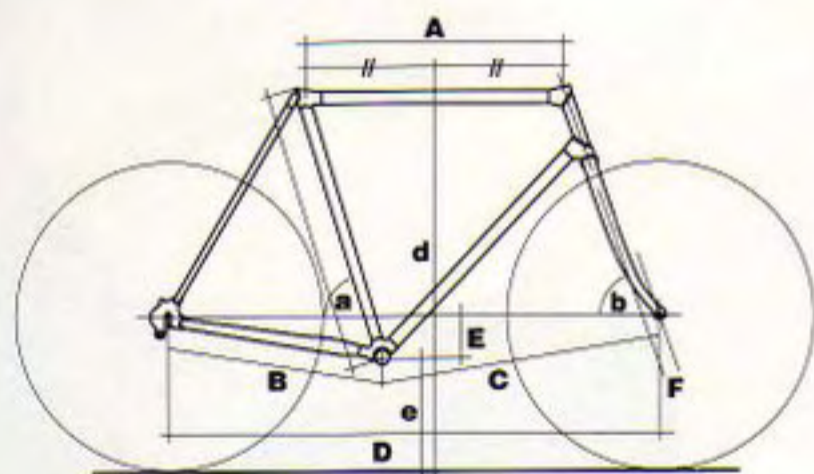

HIGH-PERFORMANCE CROSS EXCITEMENT WITH A HIGH-VALUE PRICE TAG. FEATURING A CHROME-MOLY FRAME, UNICROWN FORK, AND SMOOTH-SHIFTING 21-SPEED SHIMANO STI COMPONENTS. PLUS COMFORTABLE GEL SADDLE, SMOOTH-ROLLING CROSS TIRES ON LIGHTWEIGHT ALLOY RIMS, AND QUICK-RELEASE WHEELS FRONT AND REAR. A GREAT ALL-AROUND MACHINE — PERFECT FOR CITY OR COMMUTE RIDING.

SPORTCROSS

TUBE: IRIS BLUE, BICYCLE: FIRE RED

DUPLICROSS FRAME GEOMETRY [mm]

	A TOP TUBE	A1 TOP TUBE	B REAR CENTER	C FRONT CENTER	D WHEEL BASE	E BB DROP	F OFF SET	G HEAD ANGLE	H SEAT ANGLE	H1 SEAT ANGLE
20"-18"	605	675	435	655	1776	34	45	72°	73°	74°
18"-16"	570	647	435	650	1742	32	45	72°	74°	74°



- ① FULL CHROME-MOLY OVERSIZED FRAME
- ② FULL CHROME-MOLY UNICROWN FORK
- ③ SHIMANO DEORE HYPERGLIDE DRIVETRAIN WITH DX CRANKS AND LX DERAILLEURS WITH RAPID FIRE SHIFTERS
- ④ SHIMANO DEORE DX LOW PROFILE CANTILEVERS WITH DEORE LX LEVERS
- ⑤ ARAYA RM 17 RIMS
- ⑥ 25 X 1.5 KENDA K809 TIRES
- ⑦ CHROME-MOLY TIGGED STEM WITH ALLOY BAR
- ⑧ VETTA SHOCK ABSORBER GEL SADDLE
- ⑨ COLOR: ZINFANDEL

DUPLICROSS

TWICE THE FUN FOR STREET, TRAIL, OR DIRT RIDING. FULL CHROME-MOLY OVERSIZE FRAME AND UNICROWN FORK WITH INVESTMENT-CAST ENDS. FEATURING DEORE DX/LX HYPERGLIDE PERFORMANCE PACKAGE INCLUDING 21-SPEED STI, SEALED MECHANISM HUBS AND HEADSET, AND VETTA SHOCK ABSORBER GEL SADDLES FOR BOTH CAPTAIN AND STOKER. ULTIMATE HIS 'N' HERS BIKE, TOURER, OR WEEKEND FUN MACHINE.

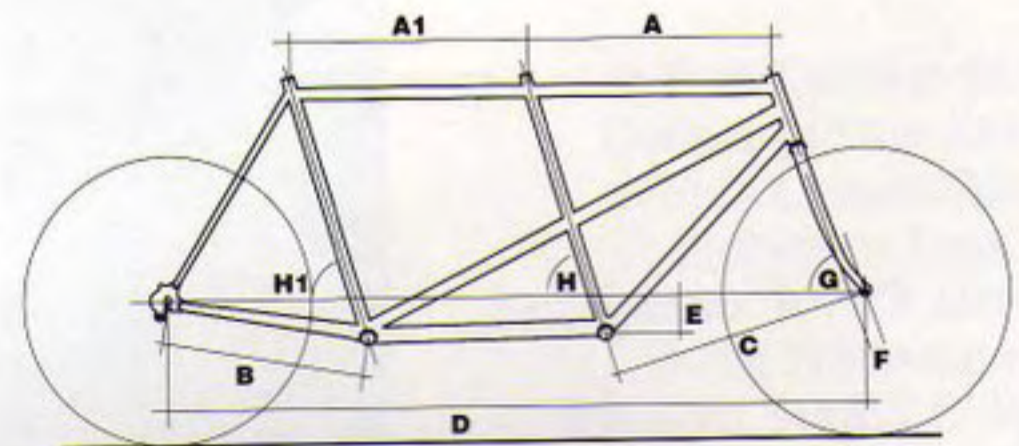

FOR THOSE WHO HAVEN'T NOTICED, MIYATA WOULD LIKE TO POINT OUT THAT MEN AND WOMEN ARE SHAPED DIFFERENTLY.

A WOMAN TENDS TO BE SMALLER IN HEIGHT THAN A MAN. SHE HAS PROPORTIONALLY LONGER LEGS AND A SHORTER WAIST. SMALLER HANDS. WIDER HIPS. AND A CENTER OF GRAVITY LOWER IN HER TORSO.

A KNOWLEDGEABLE DEALER WILL MAKE THE NECESSARY ADJUSTMENTS TO OFF-ROAD OR CROSS MACHINES WITH NO LOSS IN PERFORMANCE. BUT RACING BIKES ARE ANOTHER STORY.

FOR THE POWER OUTPUT AND HIGH SPEED CORNERING DEMANDS OF ROAD AND TRIATHLON COMPETITION, A BIKE'S WEIGHT DISTRIBUTION, SADDLE/BOTTOM BRACKET POSITION, CRANK LENGTH AND STEM/TOP TUBE EXTENSIONS ARE ALL CRUCIAL. AND, FROM A WOMAN'S POINT OF VIEW, ALL WRONG.

WHICH IS WHY MIYATA HAS INTRODUCED A SERIES OF TOP-QUALITY RACING BICYCLES CORRECTLY PROPORTIONED FOR THE FEMALE ANATOMY. WITH SMALLER, 26" WHEELS WHICH JUST HAPPEN TO WEIGH LESS AND ACCELERATE FASTER THAN THE STANDARD 700C.

THE PAVÉA RACING SERIES. HIGH-PERFORMANCE, GENDER-SPECIFIC ROAD MACHINES FOR FITNESS, FOR PERFORMANCE RIDING, AND FOR COMPETITION. AND MAYBE, IF YOU'RE PART OF THAT 52% OF THE POPULATION, FOR YOU.



**MIYATA OPTIMUM DESIGN
WOMEN'S SADDLE**

This saddle is specially designed to fit a woman's anatomy, with a wider flare and a shorter nose. Plus a special relieved center section to prevent pressure and numbness in sensitive areas, and shock-absorbing gel layer for added comfort.



**DIA COMPE COMPACT
AERO LEVERS**

Smaller, anatomically-contoured brake levers are sized to fit smaller hands perfectly. With shorter reach (the distance your hand has to move to get from the bar to the lever) to keep brakes accessible for sudden stops and prevent fatigue on long descents.

More and more women are taking their cycling seriously. And now Miyata offers a serious choice for the woman who wants a bicycle that fits right and has all the performance features she wants. The choice is Pavéa.





PAVÉA 77
TUBE: CANDY RED
BICYCLE: MYSTIC BLUE



PAVÉA 55
TUBE: AMETHYST
BICYCLE: PEARL WHITE



PAVÉA 77

RACE-READY PERFORMANCE FOR THE SMALL WOMAN RIDER. COMPLETE WITH 26" WHEELS, 165MM CRANKS, NARROW-WIDTH BARS, AND MIYATA OPTIMUM DESIGN WOMEN'S SADDLE AND COMPACT BRAKE LEVERS. ALL BUILT AROUND A PREMIUM DOUBLE-BUTTED CHROME-MOLY FRAME, UNICROWN FORK, AND SHIMANO 105 RACING COMPONENTS WITH CLIPLESS RACING PEDALS.

- ❶ FULL CHROME-MOLY DOUBLE BUTTED FRAME
- ❷ FULL CHROME-MOLY UNICROWN FORK
- ❸ SHIMANO 105 DERAILLEURS WITH HYPERGLIDE
- ❹ SHIMANO 105 SLR BRAKES WITH COMPACT LEVERS
- ❺ MIYATA SPECIAL DESIGN GEL SADDLE
- ❻ COLORS: MYSTIC BLUE OR CANDY RED

PAVÉA 55

IDEAL FOR FAST FITNESS RIDING OR THE FIRST-TIME WOMAN RACER. PREMIUM DOUBLE-BUTTED CHROME-MOLY FRAME AND FORK PLUS 7-SPEED SHIMANO 500EX HYPERGLIDE GROUP. CORRECTLY-PROPORTIONED COMPONENTS, MIYATA OPTIMUM DESIGN WOMEN'S SADDLE AND 26" TIRES.

- ❶ FULL CHROME-MOLY DOUBLE BUTTED FRAME
- ❷ FULL CHROME-MOLY UNICROWN FORK
- ❸ SHIMANO 500EX DERAILLEURS WITH HYPERGLIDE
- ❹ SHIMANO 500EX SLR BRAKES WITH COMPACT LEVERS
- ❺ MIYATA SPECIAL DESIGN GEL SADDLE
- ❻ COLORS: PEARL WHITE OR AMETHYST

PAVÉA 77 & 55 FRAME GEOMETRY ON PAGE 35

F

OR THE RACING CYCLIST, EVEN THE SMALLEST DETAIL CAN MEAN THE DIFFERENCE BETWEEN SOLO VICTORY AND A MID-PACK FINISH. SO THE SERIOUS CYCLIST CONSIDERS EVERYTHING CAREFULLY. TRAINING. NUTRITION. TERRAIN. WEATHER. TACTICS. AND EQUIPMENT. ESPECIALLY EQUIPMENT.

WHICH BRINGS US TO MIYATA RACING BICYCLES. AND THE SPECIAL TEAM DESIGNS WE PROVIDE TO OUR EUROPEAN AND AMERICAN ROAD SQUADS. AVAILABLE IN TITANIUM, ADVANCED COMPOSITE, OR SPLINED TRIPLE-BUTTED CHROME-MOLY, THESE BIKES ARE SERIOUS TOOLS FOR THE WORKING PROFESSIONAL. BUILT TO TRIUMPH IN THE MOST GRUELING EVENTS ON THE INTERNATIONAL PRO/AM CALENDAR. THE VERY SAME DESIGNS, IN FACT, WAITING FOR YOU NOW AT YOUR MIYATA DEALER.

SEVEN VERY LIGHT, VERY STIFF, VERY RESPONSIVE STATE-OF-THE-ART ROAD RACING MACHINES. EACH ONE DESIGNED WITH THE PRECISION AND ATTENTION TO DETAIL THAT HAVE MADE THE MIYATA NAME LEGENDARY IN INTERNATIONAL RACING FOR A FULL CENTURY.

So as long as you're going to train this hard, does it really make sense to do it on anything but the best equipment you can get? Miyata racing bicycles, a proud tradition.

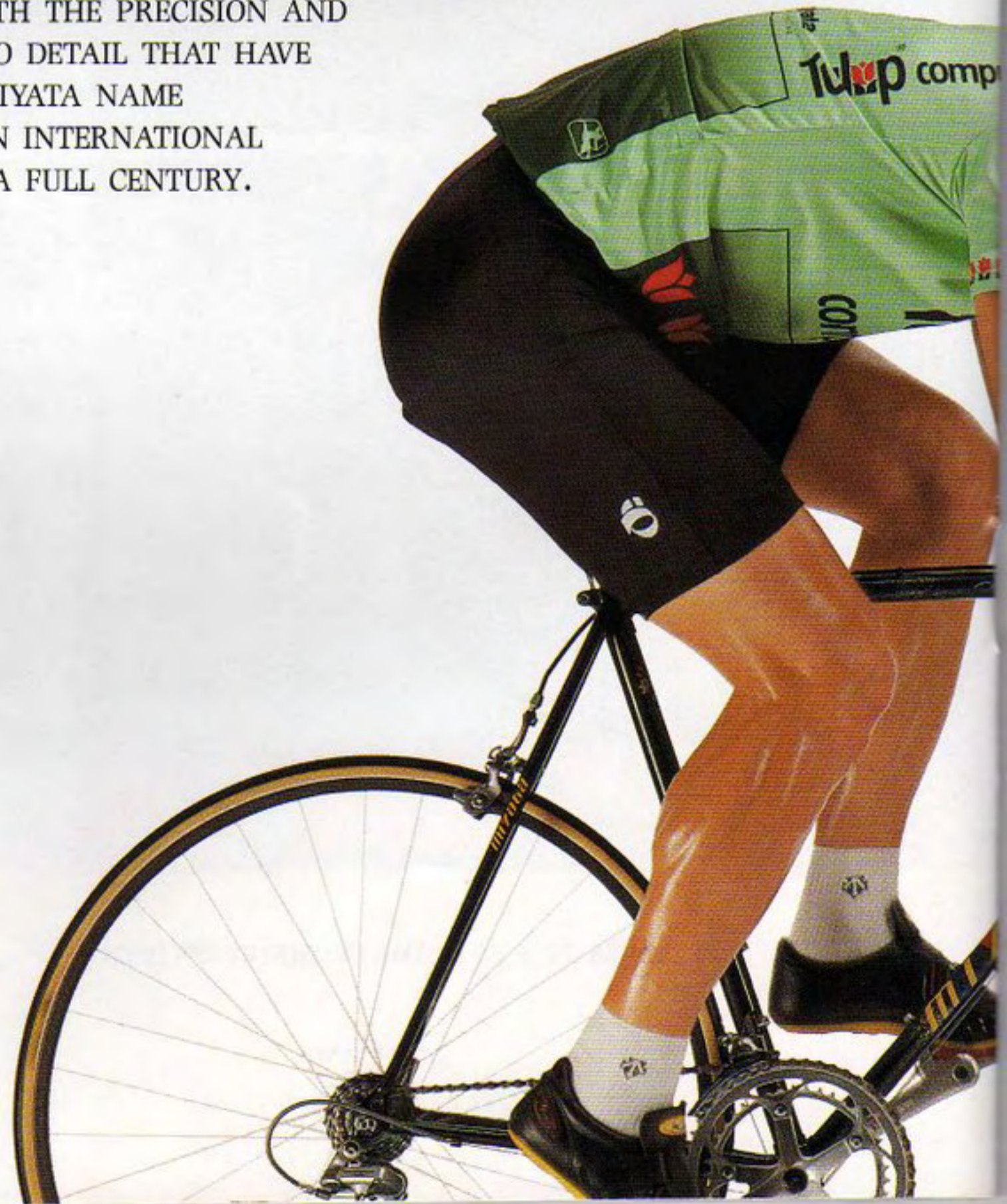

TEAM TITANIUM & TEAM CARBON FRAME GEOMETRY [mm]

	A	B	C	D	E	F	a	b	d	e
	TOP	REAR	FRONT	WHEEL	BB	OFF	HEAD	SEAT	STAND	BB
cm	TUBE	CENTER	CENTER	BASE	DROP	SET.	ANGLE	ANGLE	OVER HT	HEIGHT
0	520	408	580	984	63	55	71°	73°	730	271
0	520	408	583	982	63	55	71°	73°	750	272
2	535	408	583	982	63	45	72°	74°	763	272
4	535	408	583	982	68	45	72°	74°	782	267
6	560	408	595	993	72	35	73°	75°	793	263
8	560	408	595	993	72	35	73°	75°	812	263
0	570	408	608	1005	72	35	73.5°	75°	834	263
3	580	408	608	1005	73	35	73.5°	75°	862	262

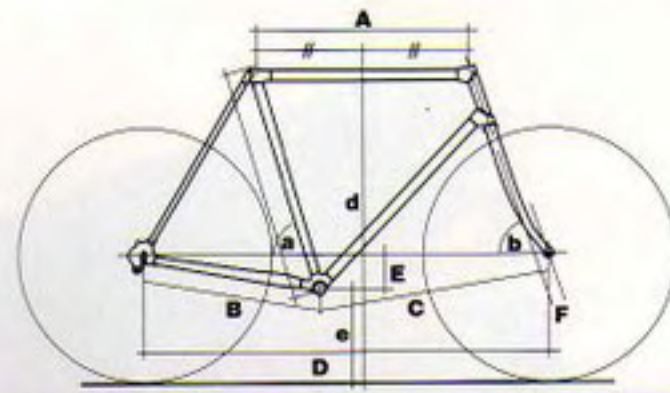

- ① FULL TITANIUM APA BONDED FRAME
- ② ALUMINUM BONDED FORK
- ③ SHIMANO ULTEGRA STI HYPERGLIDE DRIVETRAIN AND DERAILLEURS
- ④ SHIMANO ULTEGRA SUPER SLR BRAKES WITH STI INTEGRATED LEVERS
- ⑤ CAMPAGNOLO OMEGA STRADA 32H RIMS
- ⑥ 700 X 25C AVOCET FASGRIP TIRES
- ⑦ SR MODULO ANATOMIC BEND HANDLEBAR
- ⑧ SELLE ITALIA TURBO SPECIAL SADDLE
- ⑨ SHIMANO CLIPLESS PEDALS
- ⑩ COLOR: BLAZE II (POLISHED TITANIUM WITH RED)

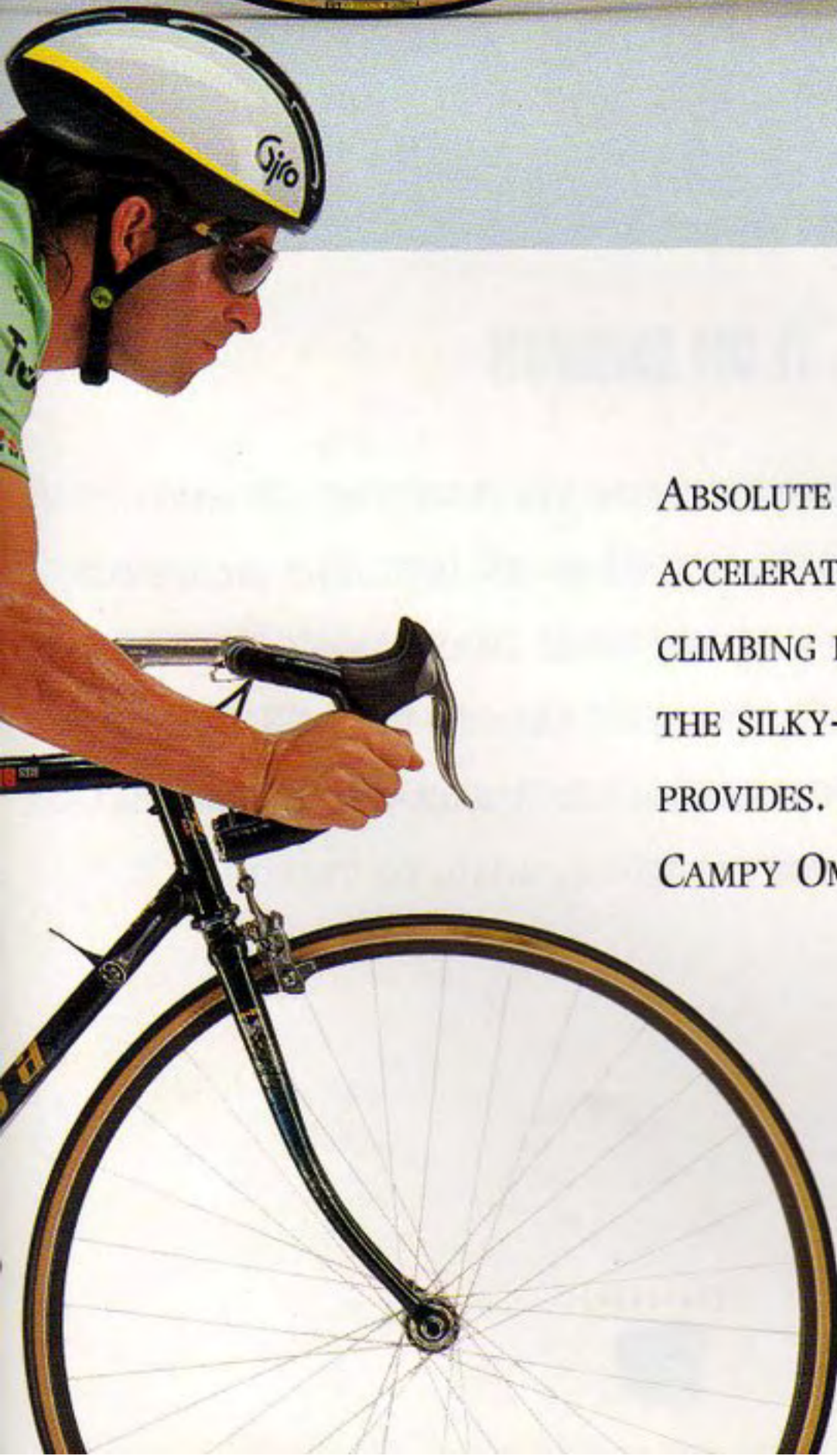

TEAM TITANIUM

ABSOLUTE TOP OF THE LINE. THREE POINT FOUR POUNDS OF LIGHTNING ACCELERATION, CORNERING PRECISION, AND FLAT-OUT SPRINTING AND CLIMBING POWER. MUCH LIGHTER THAN PREMIUM STEEL FRAMES, WITH THE SILKY-SMOOTH RIDE AND INCOMPARABLE RESILIENCE ONLY TITANIUM PROVIDES. BONDED ALUMINUM FORK, FULL 8-SPEED ULTEGRA STI, CAMPY OMEGA STRADA RIMS AND AVOCET FASGRIP CLINCHERS.

TEAM TITANIUM & TEAM CARBON FRAME GEOMETRY [mm]

	A TOP TUBE	B REAR CENTER	C FRONT CENTER	D WHEEL BASE	E BB DROP	F OFF SET.	a HEAD ANGLE	b SEAT ANGLE	d STAND OVER HT	e BB HEIGHT
48cm	520	408	580	984	63	55	71°	73°	730	
50cm	520	408	583	982	63	55	71°	73°	750	272
52cm	535	408	583	982	63	45	72°	74°	763	272
54cm	535	408	583	982	68	45	72°	74°	782	267
56cm	560	408	595	993	72	35	73°	75°	793	263
58cm	560	408	595	993	72	35	73°	75°	812	263
60cm	570	408	608	1005	72	35	73.5°	75°	834	263
63cm	580	408	608	1005	73	35	73.5°	75°	862	262



- ① FULL CARBON FIBER APA BONDED FRAME
- ② ALUMINUM BONDED FORK
- ③ SUNTOUR SL DRIVETRAIN AND DERAILLEURS
- ④ SUNTOUR SL WITH AERO LEVERS
- ⑤ WOLBER GTX II S.H. ANODIZED 32H RIMS
- ⑥ 700 X 25C AVOCET FASGRIP TIRES
- ⑦ SR MODOLO ANATOMIC BEND HANDLEBAR
- ⑧ SELLE ITALIA TURBO SADDLE
- ⑨ SHIMANO CLIPLESS PEDALS
- ⑩ COLOR: NATURAL CARBON WITH RED



CARBON TUBE

MIYATA'S APA BONDED CARBON FIBER FRAME IS STRONGER AND STIFFER THAN CHROME-MOLY STEEL YET ABSORBS SHOCK NEARLY 7 TIMES BETTER.

TEAM CARBON

SHOCK ABSORBING APA-BONDED COMPOSITE CONSTRUCTION AND ALUMINUM FORK MAKE THE TEAM CARBON AN EXCELLENT CHOICE FOR LONG-DISTANCE RACING OR CENTURY RIDES. ADD A PRIMO SUNTOUR SL GROUP AND COMPETITION FEATURES LIKE MODOLO-BEND SR BARS AND CLIPLESS RACING PEDALS, AND YOU'VE GOT A RACE-READY PERFORMANCE MACHINE THAT'S PERFECT FOR CRITERIUM, ROAD, OR TRIATHLON COMPETITION.

NINE 16 FRAME GEOMETRY [mm]

	A TOP TUBE	B REAR CENTER	C FRONT CENTER	D WHEEL BASE	E BB DROP	F OFF SET.	a HEAD ANGLE	b SEAT ANGLE	d STAND OVER HT	e BB HEIGHT
50cm	520	399	585	975	65	50	70.5°	74°	747	270
52cm	520	399	585	975	70	50	70.5°	74°	760	265
54cm	545	399	585	975	70	35	72°	74°	778	265
56cm	560	399	585	975	72	35	73°	74°	795	263
58cm	560	399	585	975	72	35	73°	74°	814	263
60cm	570	399	600	985	72	35	73°	74°	833	263
63cm	580	399	605	995	72	35	73.5°	74°	863	263

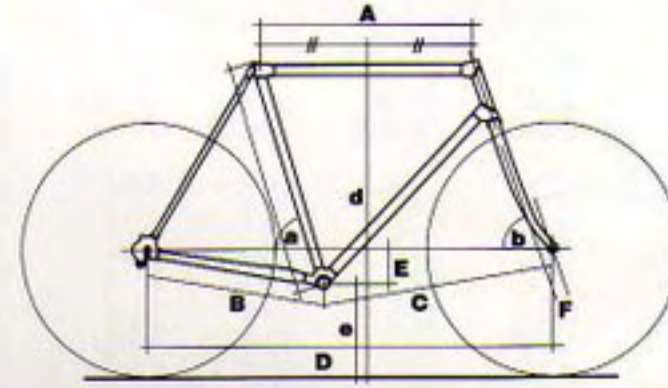

- ① EXCLUSIVE STB CHROME-MOLY FRAME
- ② EXCLUSIVE SPLINE-BLADED CHROME-MOLY FORK
- ③ SHIMANO ULTEGRA HYPERGLIDE DRIVETRAIN AND DERAILLEURS
- ④ SHIMANO ULTEGRA SUPER SLR BRAKES WITH AERO LEVERS
- ⑤ WOLBER GTX II S.H. ANODIZED 32H RIMS
- ⑥ 700 X 25C TECHNOVA II TIRES
- ⑦ SR MODULO ANATOMIC BEND HANDLEBAR
- ⑧ SELLE ITALIA TURBO SADDLE
- ⑨ SHIMANO CLIPLESS PEDALS
- ⑩ COLOR: BLACK COSMOS

NINE 16

A CHROME-MOLY MASTERPIECE, RACE-READY FROM THE STARTING GUN. CUSTOM-DRAWN SPLINED TRIPLE-BUTTED TUBING, INVESTMENT-CAST SEAT LUG, AND IMMACULATE MIYATA WORKMANSHIP THROUGHOUT. WITH 8-SPEED ULTEGRA DRIVETRAIN, DUAL-PIVOT SUPER SLR AERO BRAKES, CLIPLESS PEDALS AND A VERITABLE ARSENAL OF COMPETITION EXTRAS.



NINE 14 FRAME GEOMETRY [mm]

	A TOP TUBE	B REAR CENTER	C FRONT CENTER	D WHEEL BASE	E BB DROP	F OFF SET.	a HEAD ANGLE	b SEAT ANGLE	d STAND OVER HT	e BB HEIGHT
50cm	520	415	583	994	65	55	70.5°	73°	749	270
52cm	520	415	583	994	65	55	70.5°	73°	768	265
54cm	540	415	588	994	70	50	71.5°	73°	780	265
56cm	550	415	594	998	72	50	72°	73°	797	263
58cm	550	415	594	998	72	50	72°	73°	816	263
60cm	560	415	594	998	72	45	72.5°	73°	836	263
63cm	570	415	599	1004	72	45	73°	73°	864	263

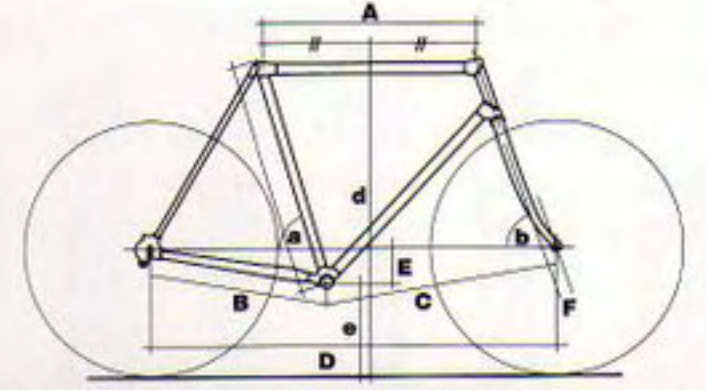

- ① EXCLUSIVE STB CHROME-MOLY FRAME
- ② FULL CHROME-MOLY FORK
- ③ SHIMANO 105 HYPERGLIDE DRIVETRAIN AND DERAILLEURS
- ④ SHIMANO 105 SUPER SLR BRAKES WITH AERO LEVERS
- ⑤ WOLBER GTA II 32H RIMS
- ⑥ 700 X 25C TECHNOVA II TIRES
- ⑦ SR ALLOY RACING BEND HANDLEBAR
- ⑧ SELLE ITALIA MUNDIALITA SPECIAL SADDLE
- ⑨ COLORS: BLUE COSMOS OR CANDY RED



CHROME-MOLY TUBE/LUG

DYNAMICALLY MATCHED TO THE FRAMES STRESSES, MIYATA'S EXCLUSIVE STB TRIPLE-BUTTED CHROME-MOLY RESULTS IN FRAMES THAT ARE LIGHTER AND SIGNIFICANTLY STRONGER.

NINE 14

STIFF, RESILIENT STB CHROME-MOLY FRAME AND FORK, SHIMANO 105 RACING COMPONENTS, MODOLO-BEND SR ANATOMIC BARS AND MICRO-ADJUSTING SEATPOST, SELLE ITALIA SADDLE. A LIGHTWEIGHT, ROCK-SOLID POWERHOUSE BUILT FOR THAT MOMENT IN EVERY RACE WHEN THE PACK SIGHTS THE FINISH LINE, AND THE HAMMER COMES DOWN.

SEVEN 14 & SEVEN 21 FRAME GEOMETRY [mm]

	A TOP TUBE	B REAR CENTER	C FRONT CENTER	D WHEEL BASE	E BB DROP	F OFF SET.	a HEAD ANGLE	b SEAT ANGLE	d STAND OVER HT	e BB HEIGHT
48cm	515	415	580	990	53	65	71°	72°	740	283
50cm	525	415	580	990	55	55	71°	72°	760	281
52cm	535	415	588	996	58	55	71°	72°	775	278
54cm	550	415	596	1003	63	50	72°	73°	790	273
56cm	550	415	596	1003	63	50	72°	73°	805	273
58cm	565	415	604	1010	66	45	72.5°	73.5°	820	270
60cm	565	415	604	1010	67	45	72.5°	73.5°	840	269



SEVEN 14

GREAT FITNESS OR TOURING BIKE BUILT AROUND AN EXTRA-RIGID APA-BONDED AIRCRAFT-GRADE ALUMINUM FRAME AND CHROME-MOLY REAR TRIANGLE AND FORK. COMPLETE WITH 7-SPEED SHIMANO 500EXAGE HYPERGLIDE COMPETITION PACKAGE AND ALL THE TRIMMINGS.

- ① ALUMINUM APA BONDED FRAME
- ② FULL CHROME-MOLY FORK
- ③ SHIMANO 500EX DERAILLEUR WITH HYPERGLIDE
- ④ SHIMANO 500EX BRAKES WITH AERO LEVERS
- ⑤ AVOCET RACING GEL SADDLE
- ⑥ COLORS: FLAME RED OR NIGHT SKY BLUE

SEVEN 21

RIGID ALUMINUM MAIN FRAME, FORGIVING CHROME-MOLY REAR TRIANGLE, WIDE-RANGE GEARING AND FULL RACK MOUNTS MAKE THE SEVEN 21 A PERFECT GETAWAY MACHINE FOR LOST WEEKENDS — OR WEEKS. 500LX 21-SPEED GROUP, AVOCET GEL SADDLE, 21-SPEED INDEXED SHIFTING.

- ① ALUMINUM APA BONDED FRAME
- ② FULL CHROME-MOLY FORK
- ③ SHIMANO 500LX DERAILLEUR WITH HYPERGLIDE
- ④ SHIMANO 500EX BRAKES WITH AERO LEVERS
- ⑤ AVOCET RACING GEL SADDLE
- ⑥ COLORS: SIERRA GREEN OR PLATINUM

700 GT FRAME GEOMETRY [mm]

	A TOP TUBE	B REAR CENTER	C FRONT CENTER	D WHEEL BASE	E BB DROP	F OFF SET.	a HEAD ANGLE	b SEAT ANGLE	d STAND OVER HT	e BB HEIGHT
50cm	540	450	604	1051	40	50	70.5°	72.5°	787	305
54cm	550	450	596	1039	60	50	71.5°	72.5°	798	285
57cm	565	450	605	1047	65	50	72°	72.5°	820	270
60cm	580	450	620	1062	65	50	72°	72.5°	849	270
63cm	580	450	620	1062	65	50	72°	72.5°	878	270

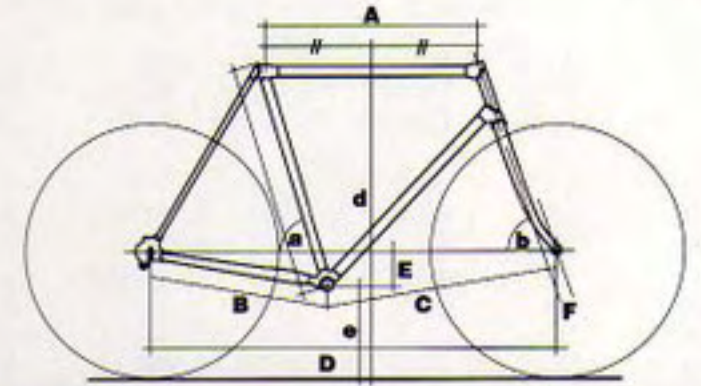

- ① EXCLUSIVE STB CHROME-MOLY FRAME
- ② EXCLUSIVE OVAL CHROME-MOLY UNICROWN FORK
- ③ SUNTOUR XCE DRIVETRAIN AND DERAILLEURS WITH BAR END SHIFTERS
- ④ DIA COMPE XCE CANTILEVER BRAKES WITH HOODED LEVERS
- ⑤ SR ALLOY HANDLEBAR
- ⑥ AVOCET GEL SADDLE
- ⑦ COLOR: NAPA GREEN



700 GT

A CLASSIC TOURING BIKE, SUITABLE FOR EVERYTHING FROM SHORT TOURS TO TRANS-WORLD EXPEDITIONS. PROVEN STB CHROME-MOLY FRAMESET COMPLETE WITH WIDE-RANGE SUNTOUR XCE COMPONENTS, CANTILEVER BRAKES, BAR-END INDEXED SHIFTERS... AND BRAZE-ONS FOR ABSOLUTELY EVERYTHING.



1 TEAM TITANIUM FRAMESET: FULL APA-BONDED TITANIUM FRAME WITH LIGHTWEIGHT ALUMINUM FORK. INCOMPARABLE RIDE AND ROAD FEEL. **2 TEAM CARBON FRAMESET:**

SHOCK ABSORBENT ADVANCED COMPOSITE FRAME APA-BONDED TO PRECISION-CAST ALUMINUM LUGS. ALUMINUM FORK.

3 TEAM MIYATA FRAMESET: THE PROFESSIONAL STANDARD. SPLINED TRIPLE-BUTTED FRAME AND FORK, FULL INVESTMENT-CAST MIYATA EXCLUSIVE LUGS.

4 ELEVATION 10,000' FRAMESET: SUPERLIGHT APA-BONDED COMPOSITE FRAME WITH DELTA FORCE SEAT STAYS, ECCENTRIC BOTTOM BRACKET, FAT MAX II CHROME-MOLY FORK.

5 ELEVATION 8,000' FRAMESET: APA-BONDED, POLISHED TITANIUM FRAME WITH ADJUSTABLE ROCK SHOX II OIL-DAMPED SUSPENSION FORK.

6 ELEVATION 5,000' FRAMESET: LIGHT, STIFF, AND RUGGED. OVERSIZE APA-BONDED ALUMINUM FRAME, AIR COBRA CHAIN STAYS AND FAT MAX II CHROME-MOLY FORK.



7 MIYATA UNICYCLES: PRECISION BALANCED, CHROMED STEEL CONSTRUCTION. PREFERRED EQUIPMENT FOR ACROBATS AND JUGGLERS WORLDWIDE.



ELEVATION

	ELEV. 10,000'	ELEV. 8,000'	ELEV. 7,000'	ELEV. 5,000'	ELEV. 3,000'	ELEV. 2,000'	ELEV. 1,000'	ELEV. 500'	
FRAME	MIYATA EXCLUSIVE BONDED OVERSIZE FULL CARBON FIBER. CARBON STAYS. PRECISION CAST ALUMINUM HEAD LUG, SEAT LUG, & BB. SHELL. ALLOY FORGED VERTICAL ENDS. TRIPLE TWO-PIECE TOP TUBE CABLE GUIDES	MIYATA EXCLUSIVE OVERSIZED TITANIUM MAIN FRAME BONDED TO PRECISION CAST ALUMINUM LUGS. TITANIUM SEAT & CHAIN STAYS. ALLOY FORGED ENDS. TRIPLE TWO-PIECE TOP TUBE CABLE GUIDES	MIYATA EXCLUSIVE BONDED OVERSIZE CARBON FIBER MAIN. ALUMINUM STAYS. CAST ALUMINUM HEAD LUG, SEAT LUG, & BB. SHELL. ALLOY FORGED VERTICAL ENDS. TRIPLE TWO-PIECE TOP TUBE CABLE GUIDES	MIYATA EXCLUSIVE BONDED OVERSIZE FULL ALUMINUM. CAST ALUMINUM HEAD LUG, SEAT LUG, & BB. SHELL. ALLOY FORGED VERTICAL ENDS. TRIPLE TWO-PIECE TOP TUBE CABLE GUIDES	MIYATA EXCLUSIVE BONDED OVERSIZE CARBON FIBER MAIN WITH CR-MO STAYS. CAST ALUMINUM HEAD LUG, SEAT LUG, & BB. SHELL. ALLOY FORGED VERTICAL ENDS. TRIPLE TWO-PIECE TOP TUBE CABLE GUIDES	MIYATA EXCLUSIVE BONDED OVERSIZE ALUMINUM MAIN WITH CR-MO STAYS. CAST ALUMINUM HEAD LUG, & B.B. SHELL. ALLOY FORGED VERTICAL ENDS. TRIPLE TWO-PIECE TOP TUBE CABLE GUIDES	MIYATA EXCLUSIVE CR-MO OVERSIZED STB. FORGED VERTICAL ENDS. TRIPLE TWO-PIECE TOP TUBE CABLE GUIDES	MIYATA EXCLUSIVE OVERSIZED STB. CR-MO. FORGED VERTICAL ENDS. TRIPLE TWO-PIECE TOP TUBE CABLE GUIDES	
FORK	FULL CR-MO UNICROWN "NEW" FAT MAX II WITH INVESTMENT CAST ENDS	FULL CR-MO UNICROWN "NEW" FAT MAX II WITH INVESTMENT CAST ENDS. ROCK SHOX OPTION AVAIL. ON FRAMESET ONLY	FULL CR-MO UNICROWN "NEW" FAT MAX II WITH INVESTMENT CAST ENDS. ROCK SHOX OPTION AVAILABLE	FULL CR-MO UNICROWN "NEW" FAT MAX II WITH INVESTMENT CAST ENDS	FULL CR-MO UNICROWN "NEW" FAT MAX II WITH INVESTMENT CAST ENDS.	FULL CR-MO UNICROWN "NEW" FAT MAX II WITH INVESTMENT CAST ENDS. ROCK SHOX OPTION AVAILABLE	FULL CR-MO UNICROWN WITH FORGED ENDS & SAFETY RETENTION DEVICE	FULL CR-MO UNICROWN WITH FORGED ENDS & SAFETY RETENTION DEVICE	
HEADSET	TANGE AP-1, 1-1/8" OVERSIZED, SEALED MECH. BLACK	TANGE AP-1, 1-1/8" OVERSIZED SEALED MECH. BLACK	TANGE AP-1, 1-1/8" OVERSIZED SEALED MECH. BLACK	TANGE AP-1, 1-1/8" OVERSIZED SEALED MECH. BLACK	TANGE AP-1, 1-1/8" OVERSIZED SEALED MECH. BLACK	TANGE AP-1, 1-1/8" OVERSIZED SEALED MECH. BLACK	YST, SEALED MECH.	YST, SEALED MECH. BLACK	
CRANKSET	SUNTOUR XC PRO MICRO DRIVE. ROUND RINGS. GREASE GUARD BB. 42/32/20	SHIMANO DEORE XT. ROUND RINGS. SILVER. 46/36/24T	SUNTOUR XC COMP MICRO DRIVE. ROUND RINGS. 42/32/20T	SHIMANO DEORE XT. ROUND RINGS. SILVER. 46/36/24T	SHIMANO DEORE DX. ROUND RINGS. SILVER. 46/36/24T	SHIMANO DEORE DX. ROUND RINGS. SILVER. 46/36/24T	SHIMANO DEORE DX. ROUND RINGS. 46/36/24T	SHIMANO DEORE LX. ROUND ALLOY RINGS. 46/36/24T	
PEDALS	SUNTOUR XC PRO W/ GREASE GUARD	SHIMANO SPD M-525 CLIPLESS	SUNTOUR XC COMP	SHIMANO SPD M-525 CLIPLESS	SHIMANO DEORE DX. CLIPS & STRAPS	SHIMANO DEORE DX. CLIPS & STRAPS	SR MTP-170, ATB CLIPS & STRAPS	SR MTP-170, ATB CLIPS & STRAPS	
DERAILLEURS	SUNTOUR XC PRO MICRO DRIVE. TOP MOUNT SHIFTERS	SHIMANO DEORE XT. TOP PULL WITH THUMB SHIFTERS	SUNTOUR XC COMP MICRO DRIVE. TOP MOUNT SHIFTERS	SHIMANO DEORE XT. TOP PULL WITH THUMB SHIFTERS	SHIMANO DEORE DX. TOP PULL WITH THUMB SHIFTERS	SHIMANO DEORE DX. TOP PULL WITH THUMB SHIFTERS	SHIMANO DEORE DX. TOP PULL WITH THUMB SHIFTERS	SHIMANO DEORE LX. TOP PULL. STI. RAPID-FIRE SHIFTER	
CLUSTER	SUNTOUR XC PRO MICRO DRIVE. POWERFLOW. 7 SPEED. 11/24T	SHIMANO DEORE XT. HYPERGLIDE. 7 SPEED. 12/28T	SUNTOUR XC COMP MICRO DRIVE. POWERFLOW. 7 SPEED. 11/24T	SHIMANO DEORE XT. HYPERGLIDE. 7 SPEED. 12/28T	SHIMANO DEORE DX. HYPERGLIDE. 7 SPEED. 12/28T	SHIMANO DEORE DX. HYPERGLIDE. 7 SPEED. 12/28T	SHIMANO DEORE DX. HYPERGLIDE. 7 SPEED. 13/30T	SHIMANO DEORE LX. HYPERGLIDE. 7 SPEED. 13/30T	
CHAIN	SUNTOUR XC PRO	SHIMANO HYPERGLIDE 90	SUNTOUR XC COMP	SHIMANO HYPERGLIDE 90	SHIMANO HYPERGLIDE 70	SHIMANO HYPERGLIDE 70	SHIMANO HYPERGLIDE 70	SHIMANO HYPERGLIDE 70	
TIRES	GREG HERBOLD SPECIAL. 26" x 2.1"	GREG HERBOLD SPECIAL. 26" x 2.1"	GREG HERBOLD SPECIAL. 26" x 2.1"	GREG HERBOLD SPECIAL. 26" x 2.1"	GREG HERBOLD SPECIAL. 26" x 2.1"	GREG HERBOLD SPECIAL. 26" x 2.1"	RITCHEY MEGABITE HARD-DRIVE. 26" x 2.0"	KENDA K-816 26" x 2.1"	
RIMS	ARAYA RM-17 SUPER HARD ANODIZED. 32H. SCHRAEDER HOLE PRESTA ADAPTER	ARAYA RM-17 ALLOY SILVER. 32H. SCHRAEDER HOLE PRESTA ADAPTER	ARAYA RM-17 ALLOY SILVER. 32H. SCHRAEDER HOLE PRESTA ADAPTER	ARAYA RM-17 ALLOY SILVER. 32H. SCHRAEDER HOLE PRESTA ADAPTER	ARAYA CV - 7 ALLOY SILVER. 32 HOLE. SCHRAEDER HOLE PRESTA ADAPTER	ARAYA CV - 7 ALLOY SILVER. 32 HOLE. SCHRAEDER HOLE PRESTA ADAPTER	ARAYA RM-17 ALLOY. SILVER. 32 HOLE SCHRAEDER	ARAYA CV-7 ALLOY. BLACK. 32HOLE SCHRAEDER	
SPOKES	HOSHI DOUBLE BUTTED STAINLESS. 14/15G	HOSHI STAINLESS 14G	HOSHI STAINLESS 14G	HOSHI STAINLESS 14G	HOSHI STAINLESS 14G	HOSHI STAINLESS 14G	STAINLESS 14G	STAINLESS 14G	
HUBS	SUNTOUR XC PRO MICRO DRIVE. SEALED. Q/R F&R FREEHUB WITH GREASE GUARD	SHIMANO DEORE XT. SEALED MECH. Q/R F&R FREEHUB	SUNTOUR XC COMP MICRO DRIVE. SEALED MECH. Q/R F&R FREEHUB	SHIMANO DEORE XT. SEALED MECH. Q/R F&R FREEHUB	SHIMANO DEORE DX. SEALED MECH. Q/R F&R FREEHUB	SHIMANO DEORE DX. SEALED MECH. Q/R F&R FREEHUB	SHIMANO DEORE DX. SEALED MECH. Q/R F&R FREEHUB	SHIMANO DEORE LX. SEALED MECH. Q/R F&R FREEHUB	
BRAKESET	SUNTOUR XC PRO SUPER LOW PROFILE.	SHIMANO DEORE XT SLR. LOW PROFILE CANTILEVER F&R WITH 2 FINGER LEVERS	SUNTOUR XC COMP SUPER LOW PROFILE.	SHIMANO DEORE XT SLR. LOW PROFILE CANTILEVER F&R WITH 2 FINGER LEVERS.	SHIMANO DEORE DX. SLR. LOW PROFILE CANTILEVER F&R WITH 2 FINGER LEVER	SHIMANO DEORE DX. SLR. LOW PROFILE CANTILEVER F&R WITH 2 FINGER LEVER	SHIMANO DEORE DX. SLR. LOW PROFILE CANTILEVER F&R W/ 2 FINGER LEVERS	SHIMANO DEORE LX. SLR. LOW PROFILE CANTILEVER F&R. 3 FINGER LEVER	
HANDLEBAR	NITTO ALLOY BUTTED BLACK	KUSUKI ALLOY. BLACK	KUSUKI ALLOY. BLACK	KUSUKI ALLOY. BLACK	KUSUKI ALLOY. BLACK	KUSUKI ALLOY. BLACK	DHM ALLOY. BLACK	HSIN LUNG ALLOY. BLACK	
STEM	ANSWER A-TAC ANODIZED	RITCHEY FORCE. TIGGED CR-MO. BLACK	RITCHEY FORCE. TIGGED CR-MO. BLACK.	RITCHEY FORCE. TIGGED CR-MO. BLACK	RITCHEY FORCE. TIGGED CR-MO. BLACK	RITCHEY FORCE. TIGGED CR-MO. BLACK	HSIN LUNG ZOOM. HEAT TREATED CR-MO	HSIN LUNG ZOOM. HEAT TREATED CR-MO	
SEAT POST	SR ALLOY. BLACK. MICRO ADJUST	SR ALLOY. BLACK. MICRO ADJUST	SR ALLOY. BLACK. MICRO ADJUST	SR ALLOY. BLACK. MICRO ADJUST	SR ALLOY. BLACK. MICRO ADJUST	SR ALLOY. BLACK. MICRO ADJUST	KALLOY CR-MO. MICRO ADJUST	KALLOY ALLOY. BLK. MICRO ADJUST	
SADDLE	GREG HERBOLD SPECIAL. LEATHER	GREG HERBOLD SPECIAL. LEATHER	GREG HERBOLD SPECIAL. LEATHER	GREG HERBOLD SPECIAL. LEATHER	GREG HERBOLD SPECIAL. LEATHER	GREG HERBOLD SPECIAL. LEATHER	VELO GEL LITE WITH EMERALD TOP	VELO GEL LITE WITH EMERALD TOP	
EXTRA FEATURES	Q/R SEAT BINDER. DUAL WATER BOTTLE FITTINGS. GREG HERBOLD GRIPS. CHAIN STAY PROTECTOR. CLEAR COAT. NEW MIYATA OPTIMUM DESIGN (MOD) FRAME	Q/R SEAT BINDER. DUAL WATER BOTTLE FITTINGS. GREG HERBOLD GRIPS. REAR RACK MNT*. CHAIN STAY PROTECTOR. CLEAR COAT. NEW MIYATA OPTIMUM DESIGN (MOD) FRAME	Q/R SEAT BINDER. DUAL WATER BOTTLE FITTINGS. GREG HERBOLD GRIPS. CHAIN STAY PROTECTOR. CLEAR COAT. REAR RACK MOUNT*. NEW MIYATA OPTIMUM DESIGN(MOD) FRAME	Q/R SEAT BINDER. DUAL WATER BOTTLE FITTINGS. GREG HERBOLD GRIPS. REAR RACK MOUNT*. CHAIN STAY PROTECTOR. CLEAR COAT. NEW MIYATA OPTIMUM DESIGN (MOD) FRAME	Q/R SEAT BINDER. DUAL WATER BOTTLE FITTINGS. GREG HERBOLD GRIPS. REAR RACK MOUNT*. CHAIN STAY PROTECTOR. CLEAR COAT. NEW MIYATA OPTIMUM DESIGN (MOD) FRAME	Q/R SEAT BINDER. DUAL WATER BOTTLE FITTINGS. GREG HERBOLD GRIPS. REAR RACK MOUNT*. CHAIN STAY PROTECTOR. CLEAR COAT. NEW MIYATA OPTIMUM DESIGN (MOD) FRAME	Q/R SEAT BINDER. DUAL WATER BOTTLE FITTINGS. GREG HERBOLD GRIPS. REAR RACK MOUNT*. CHAIN STAY PROTECTOR. CLEAR COAT. NEW MIYATA OPTIMUM DESIGN (MOD) FRAME	BLACK Q/R SEAT BINDER. DUAL WATER BOTTLE FITTINGS. REAR RACK MOUNT. CHAIN HANGER. CHAIN STAY PROTECTOR. CLEAR COAT	BLACK Q/R SEAT BINDER. DUAL WATER BOTTLE FITTINGS. REAR RACK MOUNT. CHAIN HANGER. CHAIN STAY PROTECTOR. CLEAR COAT
SIZES	14.5", 16.5", 18.5", 20.5"	14.5", 16.5", 18.5", 20.5"	14.5", 16.5", 18.5", 20.5"	14.5", 16.5", 18.5", 20.5"	14.5", 16.5", 18.5", 20.5"	14.5", 16.5", 18.5", 20.5"	14", 16", 18", 19.5", 21.5"	14", 16", 18", 19.5", 21.5"	
COLORS	NATURAL CARBON WITH HYSTERIA	NATURAL POLISHED TITANIUM	NATURAL CARBON WITH BLACK STAYS & HYSTERIA	NEW PATRIOT	NATURAL CARBON MAIN WITH BLACK STAYS & HYSTERIA	PLATINUM	CANDY RED OR CHARCOAL BLUE	PEARL WHITE OR NAPA GREEN	

*14.5" FRAME REQUIRES ADAPTER FOR RACK

ELEVATION

CROSS

	ELEV. 400'	ELEV. 300'	ELEV. 200'	ELEV. 150'	ALUMICROSS	QUICKCROSS	TRIPLECROSS	SPORTCROSS	DUPLICROSS
FRAME	MIYATA EXCLUSIVE OVERSIZED STB CR-MO. FORGED VERTICAL ENDS. TRIPLE TWO-PIECE TOP TUBE CABLE GUIDES	MIYATA EXCLUSIVE FULL CR-MO. FORGED VERTICAL ENDS. TWO-PIECE TOP TUBE CABLE GUIDES	TRI-MOLY (CR-MO MAIN). FORGED DROPOUTS. TWO-PIECE TOP TUBE CABLE GUIDES	CR-MO WITH FORGED ENDS. TWO-PIECE TOP TUBE CABLE GUIDES	MIYATA EXCLUSIVE BONDED ALUMINUM MAIN FRAME. CR-MO STAYS. PRECISION CAST ALUMINUM HEAD LUGS, SEAT LUG, & BB SHELL. FORGED VERTICAL ENDS. THROUGH TOP TUBE CABLE GUIDE	MIYATA EXCLUSIVE BONDED ALUMINUM MAIN FRAME. CR-MO STAYS. PRECISION CAST ALUMINUM HEAD LUGS, SEAT LUG, & BB SHELL. FORGED VERTICAL ENDS. THROUGH TOP TUBE CABLE GUIDE	MIYATA EXCLUSIVE CR-MO STB MAIN. FORGED VERTICAL ENDS. TWO-PIECE TOP TUBE CABLE GUIDES	CR-MO. FORGED ENDS. SPOON DESIGN SEATSTAYS. TWO-PIECE TOP TUBE CABLE GUIDES	FULL CR-MO. FISHER OVERSIZED. VERTICAL DROPOUTS. FORGED ENDS WITH EYELETS
FORK	FULL CR-MO UNICROWN WITH FORGED ENDS & SAFETY RETENTION DEVICE	CR-MO STEERER, UNICROWN WITH FORGED ENDS & SAFETY RETENTION DEVICE.	CR-MO STEERER, UNICROWN WITH SEMI-FORGED ENDS. SAFETY RETENTION DEVICE	CR-MO STEERER, UNICROWN BLADES WITH SEMI-FORGED ENDS.	FULL CR-MO UNICROWN. FORGED ENDS WITH EYELETS	FULL CR-MO UNICROWN. FORGED ENDS WITH EYELETS	FULL CR-MO UNICROWN. FORGED ENDS WITH EYELETS	UNICROWN CR-MO STEERER WITH AERO HI-TENSILE BLADES. FORGED ENDS	FULL CR-MO UNICROWN WITH INVESTMENT CAST DROPOUTS
HEADSET	YST. SEALED. BLACK	YST. SEALED. BLACK	YST	YST PRECISION, SEALED TOP LKNUT	RITCHEY LOGIC, SEALED. BLACK	SHIMANO 500LX. SEALED. BLACK	YST PRECISION STEEL. SEALED	YST PRECISION SEALED LOCKNUT	YST PRECISION SEALED. OVERSIZED
CRANKSET	SHIMANO 400LX. BIO-PACE STEEL RINGS. 48/38/28T	SUNTOUR XCM. ROUND RINGS. 48/38/28T	SHIMANO 202GS WITH ALLOY ARMS BIO-PACE RINGS. 48/38/28T	SR ALLOY. ROUND RINGS. 48/38/28T	SHIMANO DEORE DX. SUPERGLIDE. ROUND RINGS. 46/36/24T	SHIMANO 500LX. SUPERGLIDE. ROUND ALLOY RINGS. 50/40/30T	SHIMANO 300LX. SUPERGLIDE. ROUND RINGS. 50/40/30T	SHIMANO 300LX. SUPERGLIDE. ROUND RINGS. 50/40/30T	SHIMANO DEORE DX. SUPERGLIDE. ROUND RINGS. 48/38/28T
PEDALS	HTI RESIN. ATB TOE CLIPS & STRAPS	HTI RESIN ATB	WELLGO RESIN	VICTOR RESIN	SHIMANO DEORE LX	MKS RESIN. ATB CLIPS & STRAPS	WELLGO HYBRID CLIPS & STRAPS	WELLGO RESIN. HYBRID PEDAL	SHIMANO DEORE LX
DERAILLEURS	SHIMANO 400LX. TOP PULL. STI. RAPID-FIRE SHIFTRS	SUNTOUR XCM WITH THUMB SHIFTERS	SHIMANO 200GS WITH THUMB SHIFTERS	SUNTOUR XCU WITH WISHBONE SHIFTERS	SHIMANO DEORE DX. SIS. BAR END SHIFTERS	SHIMANO 400LX	SHIMANO 300LX. STI. RAPID-FIRE SHIFTERS	SHIMANO 200GS. STI. RAPID-FIRE SHIFTERS	SHIMANO DEORE LX WITH DEORE LX STI SHIFTERS
CLUSTER	SHIMANO 400LX. HYPERGLIDE. 7 SPEED. 13/30T	SUNTOUR XCM. 7 SPEED. 13/30T	SHIMANO 200GS. HYPERGLIDE. 7 SPEED. 13/30T	SUNTOUR 7 SPEED. 13/30T	SHIMANO DEORE DX HYPERGLIDE. 7 SPEED. 12/28T	SHIMANO 500LX. HYPERGLIDE. 7 SPEED. 12/28T	SHIMANO 300LX. HYPERGLIDE. 7-SPEED. 13/30T	SHIMANO 200GS. HYPERGLIDE. 7 SPEED. 13/30T	SHIMANO DEORE DX. HYPERGLIDE. 7 SPEED. 12/28T
CHAIN	SHIMANO HYPERGLIDE 50	KMC UNIGLIDE 50	KMC UNIGLIDE 50	KMC ALPHA 50	SHIMANO DEORE DX HYPERGLIDE	SHIMANO 500LX. HYPERGLIDE.	KMC HYPERGLIDE 50	KMC UNIGLIDE 50	SHIMANO HYPERGLIDE 70
TIRES	KENDA K-816 SSW. 26" x 2.1"	KENDA K-816 SSW. 26" x 2.1"	KENDA K-822 SSW. 26" x 1.95"	KENDA 26" x 1.5"	IRC CROSS COUNTRY 700 x 35c	PANARACER KHARTOUM. SSW. CROSS. 700x35c	CHENG SHIN CROSS. 700 x 35c	CHENG SHIN CROSS. 700 x 35c	KENDA K-809. 26" x 1.5"
RIMS	ARAYA VP-20. ALLOY. SILVER. 36HOLE SCHRAEDER	ARAYA VP-20. ALLOY. SILVER. 36HOLE SCHRAEDER	ARAYA VP-20. ALLOY. SILVER. 36HOLE SCHRAEDER	ARAYA MP-22. ALLOY. SILVER. 36HOLE SCHRAEDER	WOLBER GTX SUPER HARD ANODIZED. 700c. 32 HOLE. PRESTA	ARAYA PX-45. SILVER. 36HOLE. PRESTA	ARAYA PX-45. SILVER. 36HOLE. PRESTA	ARAYA SP-20. SILVER. 36HOLE. PRESTA	ARAYA RM-17. 36HOLE. SCHRAEDER.
SPOKES	STAINLESS 14G	STAINLESS 14G	STAINLESS 14G	STAINLESS 14G	HOSHI STAINLESS 14G	HOSHI STAINLESS 14G	STAINLESS 14G	STAINLESS 14G	STAINLESS 14G
HUBS	SHIMANO 400LX. SEALED MECH. Q/R F&R FREEHUB.	JOY YOU ALLOY. Q/R F&R FREEHUB	SHIMANO 200GS. Q/R F & FREEHUB	KK. STEEL. Q/R F & R. BLACK	SHIMANO DEORE DX. SEALED MECH. Q/R F&R FREEHUB	SHIMANO 500LX. Q/R F&R FREEHUB	SHIMANO 300LX. SEALED MECH. Q/R F&R FREEHUB	SHIMANO 200GS. SEALED MECH. Q/R F&R FREEHUB	SHIMANO DEORE LX. SEALED MECH. Q/R F&R FREEHUB
BRAKES	SHIMANO 400LX. SLR. LOW PROFILE CANTILEVER F&R. 3 FINGER LEVER	DIA-COMPE XCM CANTILEVER. REACH ADJUSTABLE LEVER	SHIMANO 200GS. 3 FINGER LEVER	DIA-COMPE XCT LEVER, XCT LOW PROFILE CANTILVRS F&R. DIA-COMPE U-BRAKE ON 14" BIKE	SHIMANO 105 SUPER SLR AERO LEVERS WITH DEORE DX CANTILEVERS F&R	SHIMANO 300LX CANTILEVERS WITH SHIMANO 3 FINGER LEVERS	SHIMANO 200CX CANTILEVERS WITH SHIMANO 3 FINGER LEVERS	SHIMANO 200CX CANTILEVERS WITH SHIMANO 3 FINGER LEVERS	SHIMANO DEORE DX CANTILEVERS WITH DEORE STI LEVERS & SHIFTERS
HANDLEBAR	HSIN LUNG STEEL. BLACK	HSIN LUNG STEEL. BLACK	HSIN LUNG BLACK. FLAT DOUBLETAPER	HSIN LUNG 30MM RISE. BLK ANODIZED	NITTO ALLOY SPREAD-DROP BAR	SR STEEL POWER BULGE. BLACK	HSIN LUNG BLACK. FLAT DOUBLETAPER	HSIN LUNG BLACK. FLAT DOUBLETAPER	HSIN LUNG ALLOY
STEM	HSIN LUNG TIGGED HI-TENSILE	HSIN LUNG TIGGED HI-TENSILE	HSIN LUNG TIGGED HI-TENSILE	SAMENESS STEEL. ATB STEM	NITTO DYNAMIC II. ALLOY. 90 DEGREE. BLACK ANODIZED	SR ALLOY. RISE. BLACK	HSIN LUNG TIGGED HI-TENSILE STEEL	HSIN LUNG TIGGED HI-TENSILE STEEL	HSIN LUNG TIGGED CR-MO
SEAT POST	KALLOY ALLOY. BLK. MICRO ADJUST	STEEL WITH PVC CAP	STEEL WITH PVC CAP	STEEL. WITH PVC CAP BLACK	SR TCO SPORT. ALLOY. BLACK	STRONG ALLOY. MICRO ADJUST	KALLOY ALLOY. MICRO ADJUST	KALLOY ALLOY. STRAIGHT POST	KALLOY CR-MO
SADDLE	VELO GEL LITE WITH EMERALD TOP	VELO GEL LITE WITH EMERALD TOP	VELO GEL LITE	"MIYATA" ATB SADDLE	AVOCET RACING GEL	AVOCET RACING GEL	VELO GEL LITE	VELO GEL LITE	VETTA SHOCK ABSORBER GEL
EXTRA FEATURES	BLACK Q/R SEAT BINDER. DUAL WATER BOTTLE FITTINGS. REAR RACK MOUNT. CHAIN HANGER. CHAIN STAY PROTECTOR. CLEAR COAT	DUAL WATER BOTTLE FITTINGS. REAR RACK MOUNT. CHAIN STAY PROTECTOR. CLEAR COAT	DUAL WATER BOTTLE FITTINGS (ONE FITTING ON LADIES MODEL). REAR RACK MOUNTS. CHAIN STAY PROTECTOR. CLEAR COAT	DUAL WATER BOTTLE FITTINGS (ONE FITTING ON LADIES MODEL). REAR RACK MOUNTS. CHAIN STAY PROTECTOR. CLEAR COAT. Q/R SEAT BINDER	DUAL BOTTLE FITTINGS. CHAIN-HANGER. AIR BOTTLE BASEMENT. Q/R SEAT BINDER. REAR RACK MOUNTS. PUMP PEG. CHAIN STAY PROTECTOR. CLEAR COAT	DUAL BOTTLE FITTINGS. CHAIN-HANGER. AIR BOTTLE BASEMENT. Q/R SEAT BINDER. REAR RACK MOUNTS. PUMP PEG. CHAIN STAY PROTECTOR. RITCHEY GRIPS. CLEAR COAT	Q/R SEAT BINDER. DUAL BOTTLE FITTINGS. REAR RACK MOUNTS. PUMP PEG. CHAIN STAY PROTECTOR. CLEAR COAT	Q/R SEAT BINDER. DUAL BOTTLE FITTINGS (ONE ON LADIES). REAR RACK MOUNTS. PUMP PEG. CHAIN STAY PROTECTOR. CLEAR COAT	Q/R SEAT BINDERS. TRIPLE BOTTLE FITTINGS. REAR RACK MOUNTS. RITCHEY GRIPS. PUMP PEG. CHAIN STAY PROTECTOR. CLEAR COAT
SIZES	14", 16", 18", 19.5", 21.5"	14", 16", 18", 19.5", 21.5"	14", 16", 18", 19.5", 21.5", L16" & L18"	16", 18", 19.5", 21.5", L16" & L18"	48, 50, 52, 54, 56, 58, 60cm	48, 50, 52, 54, 56, 58, 60cm	46, 50, 54, 56, 58, 60, 63cm	46, 50, 54, 56, 58, 60, 63cm L46cm, L50cm	20" x 18" & 18" x 16"
COLORS	AMETHYST OR BLUE NOVA	TAHOE GREEN OR DESERT SAND	BLACK SPARKLE OR FIRE RED	RED JASPER OR SIERRA GREEN	OPAL	MYSTIC BLUE	PLATINUM OR FOREST GREEN	FIRE RED OR IRIS BLUE	ZINFANDEL

PAVÉA 77

PAVÉA 55

TEAM
TITANIUMTEAM
CARBON

NINE 16

NINE 14

SEVEN 14

SEVEN 21

700 GT

	PAVÉA 77	PAVÉA 55	TEAM TITANIUM	TEAM CARBON	NINE 16	NINE 14	SEVEN 14	SEVEN 21	700 GT
FRAME	MIYATA EXCLUSIVE CR-MO DOUBLE BUTTED. INVESTMENT CAST SEAT LUG. SPOON STAYS. FORGED ENDS	MIYATA EXCLUSIVE CR-MO DOUBLE BUTTED. INVESTMENT CAST SEAT LUG. SPOON STAYS. FORGED ENDS WITH EYELETS	MIYATA EXCLUSIVE FULL TITANIUM MAIN FRAME BONDED TO PRECISION CAST ALUMINUM LUGS. TITANIUM SEAT AND CHAIN STAYS. FORGED ENDS	FULL MIYATA EXCLUSIVE CARBON FIBER MAIN FRAME BONDED TO PRECISION CAST ALUMINUM LUGS. CARBON FIBER SEAT & CHAIN STAYS. FORGED ENDS	MIYATA EXCLUSIVE CR-MO STB. INVESTMENT CAST SEAT LUGS. DOUBLE TAPERED SEAT STAY. FORGED ENDS.	MIYATA EXCLUSIVE CR-MO STB. DOUBLE TAPERED SEAT STAY. FORGED ENDS	MIYATA EXCLUSIVE BONDED ALUMINUM MAIN FRAME. CR-MO STAYS. PRECISION CAST ALUMINUM HEAD LUG, SEAT LUG, & BB SHELL FORGED ENDS. THROUGH TOP TUBE CABLE GUIDE	MIYATA EXCLUSIVE BONDED ALUMINUM MAIN FRAME. CR-MO STAYS. PRECISION CAST ALUMINUM HEAD LUG, SEAT LUG, & BB SHELL FORGED ENDS. THROUGH TOP TUBE CABLE GUIDE	MIYATA EXCLUSIVE OVERSIZED CR-MO STB. FORGED ENDS WITH DOUBLE EYELETS. THREE PIECE TOP TUBE CABLE GUIDES
FORK	MIYATA EXCLUSIVE FULL CR-MO UNICROWN. FORGED ENDS	MIYATA EXCLUSIVE FULL CR-MO UNICROWN. FORGED ENDS WITH EYELETS	MIYATA EXCLUSIVE FULL BONDED ALUMINUM. FORGED ALLOY ENDS	MIYATA EXCLUSIVE FULL BONDED ALUMINUM. FORGED ALLOY ENDS	MIYATA EXCLUSIVE CR-MO SPLINED BLADE. FORGED ENDS	MIYATA EXCLUSIVE CR-MO. FORGED ENDS	MIYATA EXCLUSIVE CR-MO. FORGED ENDS WITH EYELETS	MIYATA EXCLUSIVE CR-MO. FORGED ENDS WITH EYELETS	MIYATA EXCLUSIVE OVERSIZED OVAL CR-MO UNICROWN. FORGED ENDS W/ DOUBLE EYELETS
HEADSET	SHIMANO 105, SEALED MECH.	YST. SEALED MECH.	SHIMANO ULTEGRA, SEALED MECH.	SHIMANO 105, SEALED MECH.	TANGE NOVA, SEALED MECH. BLK	SHIMANO RX-100, SEALED MECH. BLK	TANGE, SEALED MECH. BLACK	TANGE, SEALED MECH. BLACK	TANGE, SEALED MECH. BLACK
CRANKSET	SHIMANO 105 SUPERGLIDE ROUND RINGS. 53/42T 165mm LENGTH	SHIMANO 500EX. BIO-PACE RINGS. 52/42T 165mm LENGTH	SHIMANO NEW ULTEGRA. SUPERGLIDE ROUND RINGS. 53/42T	SUNTOUR SL. POWER RING-ROUND. 52/42T	SHIMANO ULTEGRA. ROUND RINGS. 53/42T	SHIMANO 105. ROUND RINGS. 52/42T	SHIMANO EXAGE 500EX. BIOPACE RINGS. 52/42T	SHIMANO 500LX. BIO-PACE TRIPLE. 50/44/28T	SUGINO ROUND RINGS. 50/40/28T
PEDALS	SHIMANO 105 CLIPLESS	SHIMANO 500EX. TOE CLIPS & STRAPS	SHIMANO 105 CLIPLESS	SHIMANO 105 CLIPLESS	SHIMANO 105 CLIPLESS	MKS SILVAN LITE. BLACK	MKS EDGE ALLOY	MKS EDGE ALLOY.	MKS ALLOY, SEALED, SILVER
DERAILLEURS	SHIMANO 105	SHIMANO 500EX	SHIMANO ULTEGRA STI	SUNTOUR SL	SHIMANO ULTEGRA	SHIMANO 105	SHIMANO EXAGE 500EX. SIS	SHIMANO 500LX REAR, SHIMANO MTN LX HALF STEP FRONT. SIS	SUNTOUR XCE WITH BAR END SHIFTERS
CLUSTER	SHIMANO 105 HYPERGLIDE 7 SPEED. 13/21T	SHIMANO 500EX. HYPERGLIDE. 7 SPEED. 13/23T	SHIMANO HYPERGLIDE. 8 SPEED. 12/23T	SUNTOUR SL. 7 SPEED 13/24T	SHIMANO ULTEGRA. 8 SPEED. 12/23T	SHIMANO 105. HYPERGLIDE 7 SPEED. 13/23T	SHIMANO HYPERGLIDE 7 SPEED. 13/23T	SHIMANO HYPERGLIDE 7 SPEED. 12/28T	SUNTOUR XCE 7 SPEED. 13/30T
CHAIN	SHIMANO HYPERGLIDE	SHIMANO HYPERGLIDE	SHIMANO HYPERGLIDE 90	SUNTOUR SL AP11	SHIMANO ULTEGRA HYPERGLIDE 90	SHIMANO 105 HYPERGLIDE	SHIMANO HYPERGLIDE	SHIMANO HYPERGLIDE	SUNTOUR AP20
TIRES	SPECIALIZED TURBO. 26" x 1.0"	SPECIALIZED TURBO. 26" x 1.0"	AVOCET FASGRIP 700 x 25c	AVOCET FASGRIP 700 x 25c	MIYATA TECHNOVA II. 700 x 25c.	MIYATA TECHNOVA II. 700 x 25c	MIYATA TECHNOVA II AR KEVLAR 700 x 25c	MIYATA TECHNOVA II AR KEVLAR 700 x 25c	MIYATA RADIAL AR. 700 x 32c. SSW, KEVLAR
RIMS	SUNMETAL M-13L. 32HOLE. 26" x 20c	SUN METAL M-13L. 13HOLE. 26" x 20c	CAMPAGNOLO OMEGA STRADA HARDOX. 32HOLE. BLACK	WOLBER GTX II. SUPER HARD ANODIZED. 32 HOLE	WOLBER GTX II. SUPER HARD ANODIZED. 32 HOLE	WOLBER GTA II. SILVER 32 HOLE	ARAYA SS-45. 700c. 36HOLE. SILVER	ARAYA SS-45. 700c. 36HOLE SILVER	ARAYA VX-300. 700c. 36HOLE. SILVER
SPOKES	STAINLESS 14G	STAINLESS 14G	HOSHI 14/15G DOUBLE BUTTED STAINLESS (2 CROSS FRONT & 3 CROSS REAR)	HOSHI STAINLESS 14G	HOSHI STAINLESS 14G	HOSHI STAINLESS 14G	STAINLESS 14G	STAINLESS 14G	HOSHI STAINLESS 14G
HUBS	SHIMANO 105. SEALED MECH. Q/R F&R FREEHUB	SHIMANO 500EX. SEALED MECH. Q/R F&R FREEHUB	SHIMANO ULTEGRA. SEALED MECH. Q/R F&R FREEHUB	SUNTOUR SL. SEALED MECH. Q/R F&R FREEHUB	SHIMANO ULTEGRA. SEALED MECH. Q/R F&R FREEHUB	SHIMANO 105. SEALED MECH. Q/R F&R FREEHUB	SHIMANO ALLOY. SEALED MECH. Q/R F&R FREEHUB	SHIMANO ALLOY. SEALED MECH. Q/R F&R FREEHUB	SANSIN CE-60. SEALED MECH. ALLOY. Q/R FREEHUB
BRAKESET	SHIMANO 105. SUPER SLR WITH DIA-COMPE COMPACT AERO LEVERS	SHIMANO 500EX. SUPER SLR WITH DIA-COMPE COMPACT AERO LEVERS	SHIMANO ULTEGRA. SUPER SLR WITH STI LEVERS	SUNTOUR SL WITH AERO LEVERS	SHIMANO ULTEGRA. SUPER SLR WITH AERO LEVERS	SHIMANO 105. SUPER SLR WITH AERO LEVERS	SHIMANO EXAGE 500EX. SUPER SLR WITH AERO LEVERS	SHIMANO EXAGE 500EX. SUPER SLR WITH AERO LEVERS	DIA-COMPE XCE. CANTILEVER FRONT & REAR WITH HOODED LEVER
HANDLEBAR	SR ALLOY DROP. 37cm WIDTH. MODOLO BEND	SR ALLOY DROP. 37cm WIDTH. MODOLO BEND	SR ALLOY. SILVER. MODOLO ANATOMICAL BEND	SR ALLOY. SILVER. MODOLO ANATOMICAL BEND	SR ALLOY. SILVER. MODOLO ANATOMICAL BEND	SR ALLOY. SILVER	SR ALLOY. SILVER	SR ALLOY. SILVER	SR ALLOY. SILVER
STEM	SR ALLOY. SILVER	SR ALLOY. SILVER	SR ALLOY. SILVER. ANODIZED	SR ALLOY. SILVER	SR ALLOY. SILVER	SR ALLOY. SILVER	SR ALLOY. BLACK ANODIZED	SR ALLOY. SILVER	SR ALLOY. BLACK
SEAT POST	SR TCO SPORT. ALLOY. MICRO ADJUST	SR TCO SPORT. ALLOY. MICRO ADJUST	SHIMANO DURA ACE	SR ALLOY. MICRO ADJUST	SR ALLOY. MICRO ADJUST	SR ALLOY. MICRO ADJUST	SR ALLOY. MICRO ADJUST	SR ALLOY. MICRO ADJUST	STRONG ALLOY BLACK. MICRO ADJUST
SADDLE	VELO GEL-LITE. MIYATA OPTIMUM DESIGN (MOD)	VELO GEL-LITE. MIYATA OPTIMUM DESIGN (MOD)	SELLE ITALIA TURBO	SELLE ITALIA TURBO	SELLE ITALIA TURBO	SELLE ITALIA MUNDIALITA SPECIAL	AVOCET RACING GEL	AVOCET RACING GEL	AVOCET GEL
EXTRA FEATURES	DUAL BOTTLE FITTINGS. CHAIN STAY PROTECTOR. CLEAR COAT	DUAL BOTTLE FITTINGS. CHAIN STAY PROTECTOR. CLEAR COAT.	DUAL BOTTLE FITTINGS. CHAIN-HANGER. AIR BOTTLE BASEMENT. PUMP PEG. CLEAR COAT	DUAL BOTTLE FITTINGS. CHAIN-HANGER. AIR BOTTLE BASEMENT. PUMP PEG. CLEAR COAT	DUAL BOTTLE FITTINGS. CHAIN-HANGER. AIR BOTTLE BASEMENT. PUMP PEG. CLEAR COAT	DUAL BOTTLE FITTINGS. CHAIN-HANGER. AIR BOTTLE BASEMENT. PUMP PEG. CLEAR COAT	DUAL BOTTLE FITTINGS. CHAIN-HANGER. AIR BOTTLE BASEMENT. PUMP PEG. REAR RACK MOUNTS. CHAIN STAY PROTECTOR. CLEAR COAT	DUAL BOTTLE FITTINGS. CHAIN-HANGER. AIR BOTTLE BASEMENT. PUMP PEG. REAR RACK MOUNTS. CHAIN STAY PROTECTOR. CLEAR COAT	DUAL BOTTLE FITTINGS. CHAIN-HANGER. AIR BTTLE BASEMENT OR 3RD WATER BOTTLE FITTING. PUMP PEG REAR RACK MNTS. CHAIN STAY PROTECTOR. LOW RIDER RACK BASEMENT ON FORKS. CLEAR COAT
SIZES	44, 47, 50cm	44, 47, 50cm	48, 50, 52, 54, 56, 58, 60, 63cm	48, 50, 52, 54, 56, 58, 60, 63cm	50, 52, 54, 56, 58, 60, 63cm	50, 52, 54, 56, 58, 60, 63cm	48, 50, 52, 54, 56, 58, 60cm	48, 50, 52, 54, 56, 58, 60cm	50, 54, 57, 60, 63cm
COLORS	MYSTIC BLUE OR CANDY RED	PEARL WHITE OR AMETHYST	BLAZE II (POLISHED TITANIUM, RED FORK & LUG)	NATURAL CARBON (WITH RED FORK AND LUG)	BLACK COSMOS	BLUE COSMOS OR CANDY RED	FLARE RED OR NIGHT SKY BLUE	SIERRA GREEN OR PLATINUM	NAPA GREEN

ELEVATION SERIES GEAR CHART

ELEVATION 10,000' & 7,000'							
	11	12	14	16	18	21	24
20	47.3	43.3	37.1	32.5	28.9	24.8	21.7
32	75.6	69.3	59.4	52	46.2	39.6	34.7
42	99.3	91	78	68.3	60.7	52	45.5

ELEVATION 8,000', 5,000', 3,000', & 2,000'							
	12	14	16	18	21	24	28
24	52	44.6	39	34.7	29.7	26	22.3
36	78	66.9	58.5	52	44.6	39	33.4
46	99.7	85.4	74.8	66.4	57	49.9	42.7

ELEVATION 1,000' & 500'							
	13	15	17	20	23	26	30
24	48	41.6	36.7	31.2	27.1	24	20.8
36	72	62.4	55	46.8	40.7	36	31.2
46	92	79.7	70.4	59.8	52	46	39.9

ELEVATION 400', 300', 200' & 150'							
	13	15	17	20	23	26	30
28	56	49	43	36	32	28	24
38	76	66	58	49	43	38	33
48	96	83	73	62	54	48	42

CROSS SERIES GEAR CHART

ALUMICROSS							
	12	14	16	18	21	24	28
24	54	46.3	40.5	36	30.9	27	23.1
36	81	69.4	60.8	54	46.3	40.5	34.7
46	103.5	88.7	77.6	69	59.1	51.8	44.4

QUICKCROSS							
	12	14	16	18	21	24	28
30	67.5	57.9	50.6	45	38.6	33.8	28.9
40	90	77.1	67.5	60	51.4	45	38.6
50	112.5	96.4	84.4	75	64.3	56.3	48.2

TRIPLECROSS & SPORTCROSS							
	13	15	17	20	23	26	30
30	62.3	54	47.6	40.5	35.2	31.2	27
40	83	72	63.5	54	47	41.5	36
50	103.8	90	79.4	67.5	58.7	52	45

DUPLICROSS							
	12	14	16	18	21	24	28
28	60.7	52	45.5	40.4	34.7	30.3	26
38	82.3	70.6	61.8	54.9	47	41.2	35.3
48	104	89.1	78	69.3	59.4	52	44.6

PAVÉA SERIES GEAR CHART

PAVÉA 77							
	13	14	15	16	17	19	21
42	84	78	72.8	68.25	64.2	57.4	52
52	104	96.6	90.1	84.5	79.5	71.1	64.3

PAVÉA 55							
	13	14	15	17	19	21	23
42	84	78	72.8	64.2	57.4	52	47.5
52	104	96.6	90.1	79.5	71.1	64.3	58.8

ROAD SERIES GEAR CHART

TEAM TITANIUM & NINE 16							
	12	13	14	15	17	19	21
42	94.5	87.2	81	75.6	66.7	59.7	54
53	119.3	110.1	102.2	95.4	84.2	75.3	68.1

TEAM CARBON							
	13	14	15	17	19	21	24
42	87.2	81	75.6	66.7	59.7	54	47.3
52	108	100.3	93.6	82.6	73.9	66.9	58.5

NINE 14 & SEVEN 14							
	13	14	15	17	19	21	23
42	87.2	81	75.6	66.7	59.7	54	49.3
52	108	100.3	93.6	82.6	73.9	66.9	61

SEVEN 21							
	12	14	16	18	21	24	28
28	63	54	47.3	42	36	31.5	27
44	99	84.9	74.3	66	56.6	49.5	42.4
50	112.5	96.4	84.4	75	64.3	56.3	48.2

700 GT							
	13	15	17	20	23	26	30
28	58.2	50.4	44.5	37.8	32.9	29.1	25.2
40	83.1	72	63.5	54	47	41.5	36
50	103.8	90	79.4	67.5	58.7	51.9	45

FRAME GEOMETRY DIAGRAM

A	B	C	D	E	F	a	b	d	e
TOP TUBE	REAR CENTER	FRONT CENTER	WHEEL BASE	BB DROP	OFF SET.	HEAD ANGLE	SEAT ANGLE	STAND OVER HT	BB HEIGHT

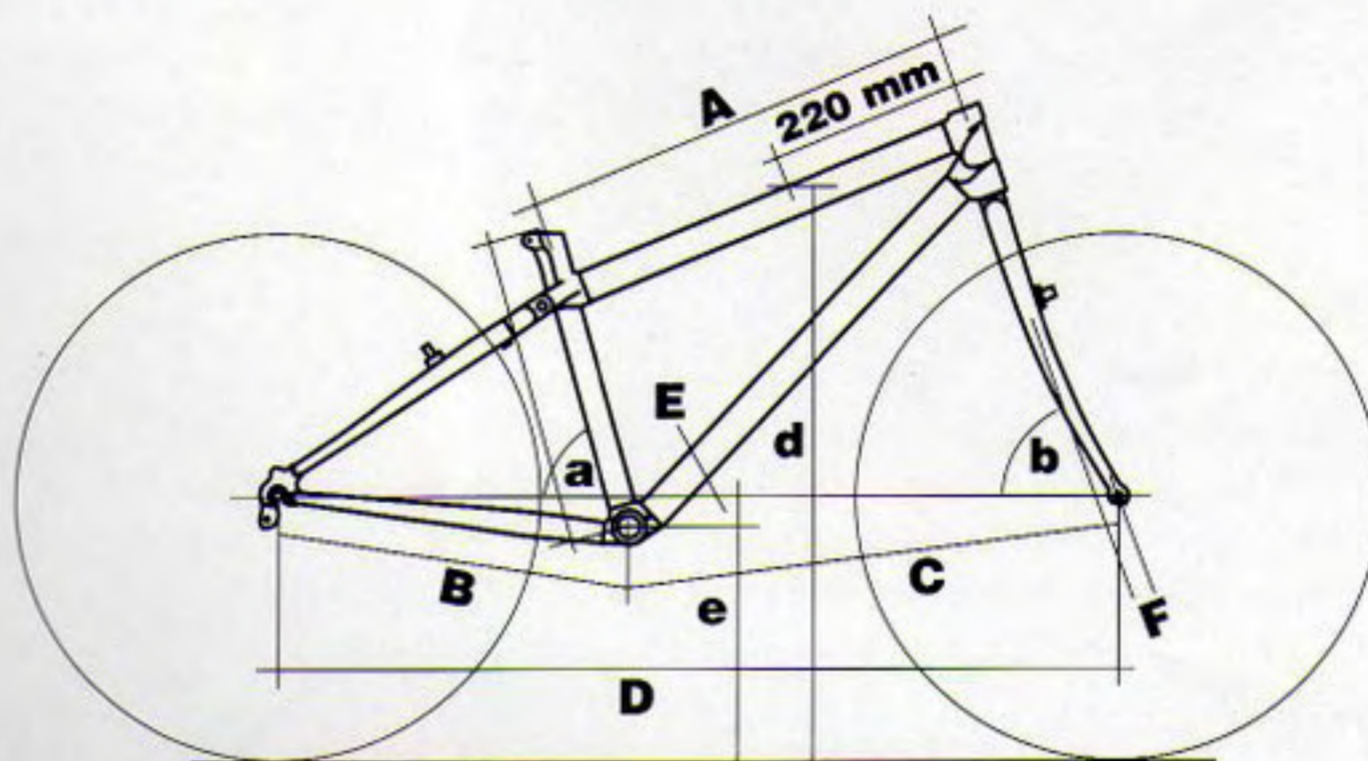

ELEVATION 10,000'
ELEVATION 8,000'
ELEVATION 7,000'
ELEVATION 5,000'
ELEVATION 3,000'
ELEVATION 2,000'

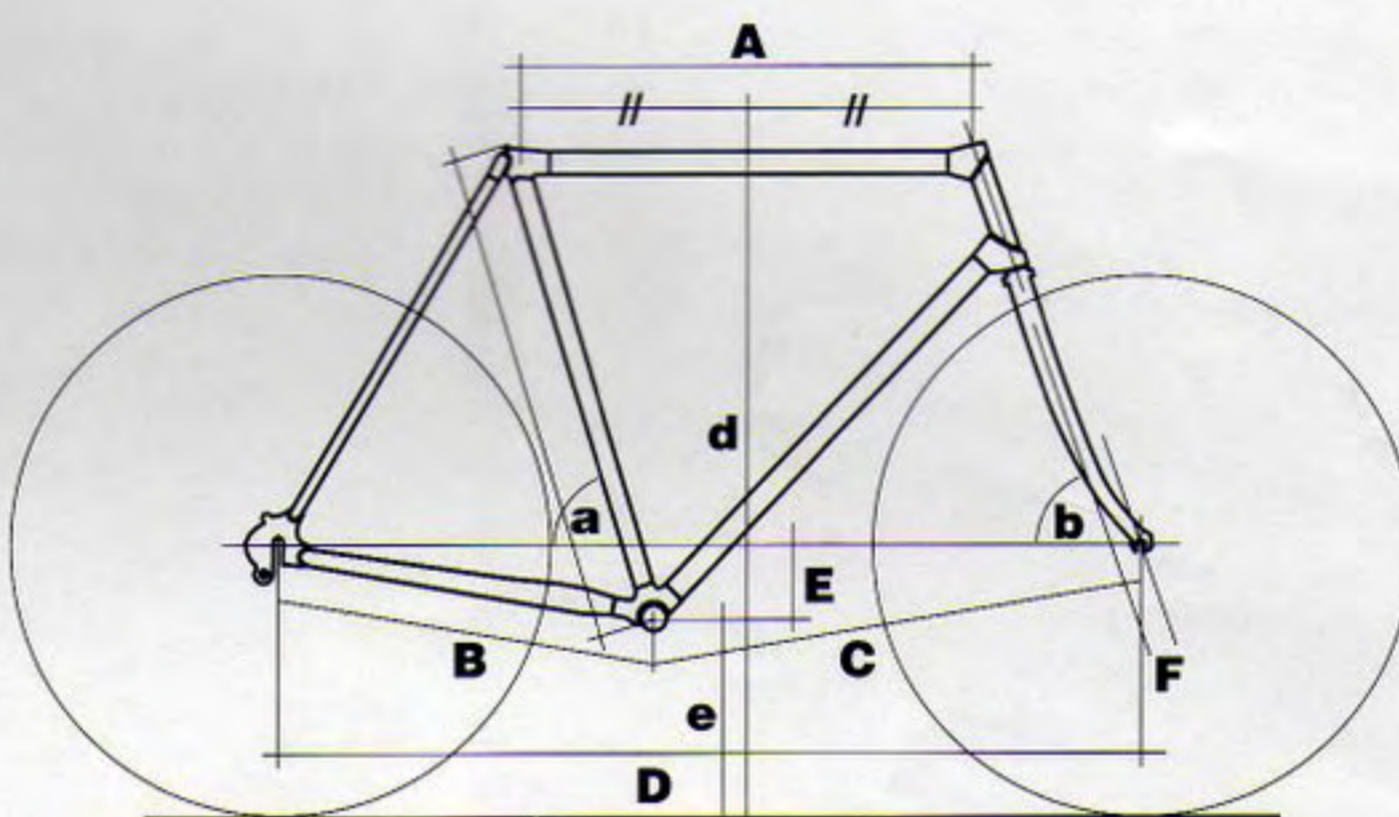

ELEVATION 1,000'
ELEVATION 500'
ELEVATION 400'
ELEVATION 300'
ELEVATION 200'
ELEVATION 150'

ALUMICROSS
QUICKCROSS
TRIPLECROSS
SPORTCROSS

PAVÉA 77
PAVÉA 55

TEAM TITANIUM
TEAM CARBON
NINE 16
NINE 14
SEVEN 14
SEVEN 21
700 GT

MISCELLANEOUS FRAME GEOMETRY

ELEVATION 1,000', 500' & 400' GEOMETRY [mm]

	A	B	C	D	E	F	a	b	d	e
	TOP TUBE	REAR CENTER	FRONT CENTER	WHEEL BASE	BB DROP	OFF SET.	HEAD ANGLE	SEAT ANGLE	STAND OVER HT	BB HEIGHT
14"	535	424	630	1051	38	48	70°	74°	704	292
16"	555	424	647	1068	38	48	70°	74°	725	292
18"	572	424	653	1074	38	48	70°	73°	760	292
19.5"	584	424	653	1074	38	48	70.5°	72.5°	773	292
21"	592	424	659	1080	38	48	70.5°	72.5°	807	292

ELEVATION 300', 200' & 150' GEOMETRY [mm]

	A	B	C	D	E	F	a	b	d	e
	TOP TUBE	REAR CENTER	FRONT CENTER	WHEEL BASE	BB DROP	OFF SET.	HEAD ANGLE	SEAT ANGLE	STAND OVER HT	BB HEIGHT
14"	535	436	630	1064	38	48	70°	74°	700	292
16"	555	436	646	1080	38	48	70°	74°	726	292
18"	572	436	653	1086	38	48	70°	73°	759	292
19.5"	584	436	653	1086	38	48	70.5°	72.5°	782	292
21.5"	592	436	661	1094	38	48	70.5°	72.5°	821	292
16"L*		436	647	1080	38	48	70°	74°	655	292
18"L*		436	653	1086	38	48	70°	73°	648	292

*16"L and 18"L is only available in Elevation 200' and 150'

PAVÉA 77 & 55 GEOMETRY [mm]

	A	B	C	D	E	F	a	b	d	e
	TOP TUBE	REAR CENTER	FRONT CENTER	WHEEL BASE	BB DROP	OFF SET.	HEAD ANGLE	SEAT ANGLE	STAND OVER HT	BB HEIGHT
44cm	462	377	548	919	50	61	70.7°	77.5°	685	282
47cm	480	377	548	919	50	61	71.7°	76.5°	712	282
50cm	498	377	555	926	50	61	71.7°	75°	736	282

THE MIYATA BICYCLE WARRANTY

A. MIYATA BICYCLE FRAMES AND FRONT FORKS ARE WARRANTED TO BE FREE FROM DEFECT IN MATERIALS AND WORKMANSHIP UNDER NORMAL USE OF THE BICYCLE FOR THE LIFETIME OF THE BICYCLE, EXCEPT IN CASES SPECIFIED IN WARRANTY EXCLUSIONS. **B.** MIYATA WARRANTIES, FOR ONE YEAR FROM DATE OF SALE, ALL PARTS EXCEPT WEARING PARTS (TIRES, TUBES, CABLES, GRIPS, SPOKES, BAR TAPES, BRAKE PADS, TOE CLIPS, STRAPS, SMALL SCREWS AND NUTS). THIS DOES NOT INCLUDE ITEMS SPECIFIED IN THE WARRANTY EXCLUSIONS. **C.** DURING THE WARRANTY PERIOD, ALL PARTS, AS DETERMINED BY MIYATA, FOUND TO BE DEFECTIVE IN WORKMANSHIP OR MATERIAL WILL BE REPAIRED OR REPLACED FREE OF CHARGE, EXCEPT FOR SHIPPING AND DEALER LABOR CHARGES (IF APPLICABLE). THIS APPLIES TO PARTS, FRAME AND FRONT FORK. **D.** RETURN OF THE WARRANTY REGISTRATION CARD TO MIYATA IS A CONDITION PRECEDENT TO COVERAGE UNDER THIS WARRANTY. THE WARRANTY REGISTRATION CARD MUST BE RETURNED TO MIYATA TO VALIDATE WARRANTY.

HOW TO CLAIM WARRANTY

A. ALL CLAIMS MADE UNDER THIS WARRANTY MUST BE MADE THROUGH AN AUTHORIZED MIYATA DEALER DURING THE RELEVANT WARRANTY PERIOD. TO OBTAIN WARRANTY SERVICE, THE OWNER MUST RETURN THE DEFECTIVE BICYCLE TO AN AUTHORIZED MIYATA DEALER FOR INSPECTION WITH THE SALES RECEIPT (OR OTHER EVIDENCE SHOWING THE DATE OF PURCHASE) AND THE OWNER RECORD IN THE OWNER'S HANDBOOK OWNER'S MANUAL. **B.** IF THE ORIGINAL DEALER IS NO LONGER AVAILABLE OR IS INCONVENIENTLY LOCATED, THE NAME OF THE AUTHORIZED DEALER NEAREST TO YOU CAN BE OBTAINED FROM MIYATA WHOSE ADDRESS IS STATED IN THIS CATALOG.

WARRANTY EXCLUSIONS

A. THIS WARRANTY COVERS ONLY THE ORIGINAL RETAIL PURCHASER OF THE BICYCLE AND IS NOT TRANSFERABLE. **B.** THIS WARRANTY DOES NOT COVER FAILURE DUE TO ACCIDENT, ABUSE, MISUSE, NEGLIGENCE, NORMAL WEAR AND TEAR, NORMAL PAINT FADING OR CHROME RUST, IMPROPER ASSEMBLY, IMPROPER FIT, IMPROPER MAINTENANCE OR USE OF UNAUTHORIZED REPLACEMENT PARTS. **C.** THIS WARRANTY DOES NOT COVER ANY PERSONAL INJURIES, DAMAGE OR FAILURE OF BICYCLE IF USED IN ANY COMPETITIVE EVENT, INCLUDING BICYCLE RACING, BICYCLE MOTOCROSS, STUNT OR SIMILAR ACTIVITIES OR WHEN USED IN TRAINING FOR THE SAME. MOTORS OR OTHER ACCESSORIES INCONSISTENT WITH THE USE INTENDED BY MIYATA WILL NEGATE THIS WARRANTY. **D.** THIS WARRANTY IS EXPRESSLY IN LIEU OF ANY OTHER WARRANTY AND ANY IMPLIED WARRANTY OF MERCHANTABILITY OR FITNESS OF ANY PURPOSE IS LIMITED IN DURATION TO THE DURATION OF THIS EXPRESS WARRANTY. MIYATA SHALL NOT BE RESPONSIBLE FOR ANY CONSEQUENTIAL OR INCIDENTAL DAMAGES. **E.** SOME STATES DO NOT ALLOW LIMITATION ON HOW LONG IMPLIED WARRANTY LASTS OR THE EXCLUSION OR LIMITATION OF INCIDENTAL OR CONSEQUENTIAL DAMAGES, SO THE ABOVE LIMITATION MAY NOT APPLY TO YOU. **F.** THIS WARRANTY DOES GIVE YOU SPECIFIC LEGAL RIGHTS, AND YOU ALSO MAY HAVE OTHER RIGHTS WHICH VARY FROM STATE TO STATE. **G.** THIS WARRANTY DOES NOT COVER FAILURE DUE TO UNLAWFUL ACTS. **H.** FAILURE TO MAINTAIN MIYATA-REQUESTED PERIODIC INSPECTIONS MAY INVALIDATE THIS WARRANTY IF SUCH FAILURE CAN BE SHOWN TO HAVE CONTRIBUTED TO THE WARRANTY PROBLEM. **I.** THIS WARRANTY IS VOID WHEN THE BICYCLE IS USED BY MANY AND UNSPECIFIC PERSONS SUCH AS RENT-A-BICYCLE BUSINESSES. **J.** THIS WARRANTY DOES NOT COVER FAILURE DUE TO EARTHQUAKE, LIGHTNING, FIRE, FLOOD, PUBLIC HAZARD, AND MAN-MADE OR NATURAL CALAMITY. **K.** THIS WARRANTY DOES NOT COVER NATURAL PHENOMENA WHICH RESULT FROM OPERATION OF THE BICYCLE, SUCH AS VIBRATIONS OR SOUNDS. **L.** THIS WARRANTY IS VOID WHEN ITEMS OUTLINED IN THE "OWNER'S RESPONSIBILITIES" SECTION ARE NOT OBSERVED.

© MIYATA BICYCLE OF AMERICA, INC. 1991 ALL RIGHTS RESERVED. CDA1075, PRINTED IN USA



MIYATA

MIYATA BICYCLE OF AMERICA, INC.
2526 W. PRATT BLVD.
ELK GROVE VILLAGE, IL 60007
800-323-8553